

I have been blessed with amazing parents, family, and friends who have helped make this book possible.

For my parents, who have always loved, supported, and encouraged me in every aspect of life. I am eternally grateful to have such incredible role models to guide me when I am lost.

For my family, who helped raise me into the person I am today. You have always watched over me, provided me with inspiration, and pushed me to pursue my goals.

For my friends, who have shared laughs, tears, all-nighters, and binge-watches. You have gotten me through the hardest parts of life and helped create the best memories.

All my love,

B → Book

01	RESEARCH	01
02	SITE	09
03	ADMINISTRATION CENTER	17
04	LIBRARY	29
05	RECREATION CENTER	37
06	CHAPEL	47
07	HOUSING	53
08	REFERENCES	63

“AN EFFECTIVE SHELTER OPERATION
BEGINS LONG BEFORE A DISASTER
STRIKES”- RED CROSS

RESEARCH

01



A natural disaster can hit anywhere and any time. When a community prepares through the use of disaster mitigation, it enables a community to be resilient in the face of adversity. Architecture can play a key role in the mitigation process by facilitating support and designing in meaningful ways that integrate emergency shelters into communities in a seamless fashion. Resource centers can be used in a multitude of ways that can benefit a town all year round. This complex combines housing, outdoor spaces, a learning center, a recreation center, and a resource based building in the rural town, La Grange, Texas. The program of the complex was developed to adapt their city to promote disaster relief and mitigation, as well as, stimulate the local economy, culture, and resident engagement. The process of combining all of the facilities in one site enables not only full access by the community, but also forms a space that can be rented out to generate an income.

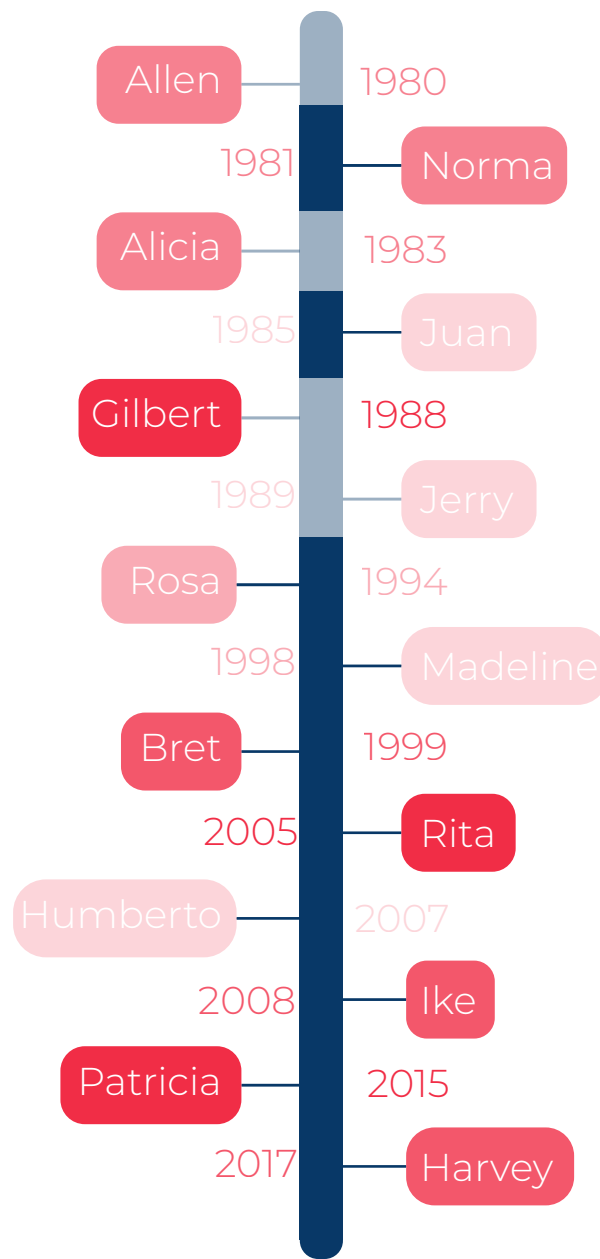

HURRICANE TIMELINE

The first step in ascertaining the problem was to check the frequency of hurricanes that have caused damage to Texas specifically. Going back to 1980, there have been a total of 14 hurricanes ranging from a Category 1 to a Category 5. While analyzing these storms, there was a focus on what the most costly issues of each storm was. The above graph shows the outcomes of each storm. The light blue section indicates wind was the main source of damage in the storm; whereas, the navy blue section shows that flooding was. By putting together this chart, it shows a clear increase in the need for more flood resistant buildings and architecture; that can withstand stronger and more frequent storms that are predicted for the future. Using architecture as a facilitator, the program of this complex creates a dialog of integrating common architecture with disaster mitigation practices that can give a community the tools to be resilient.

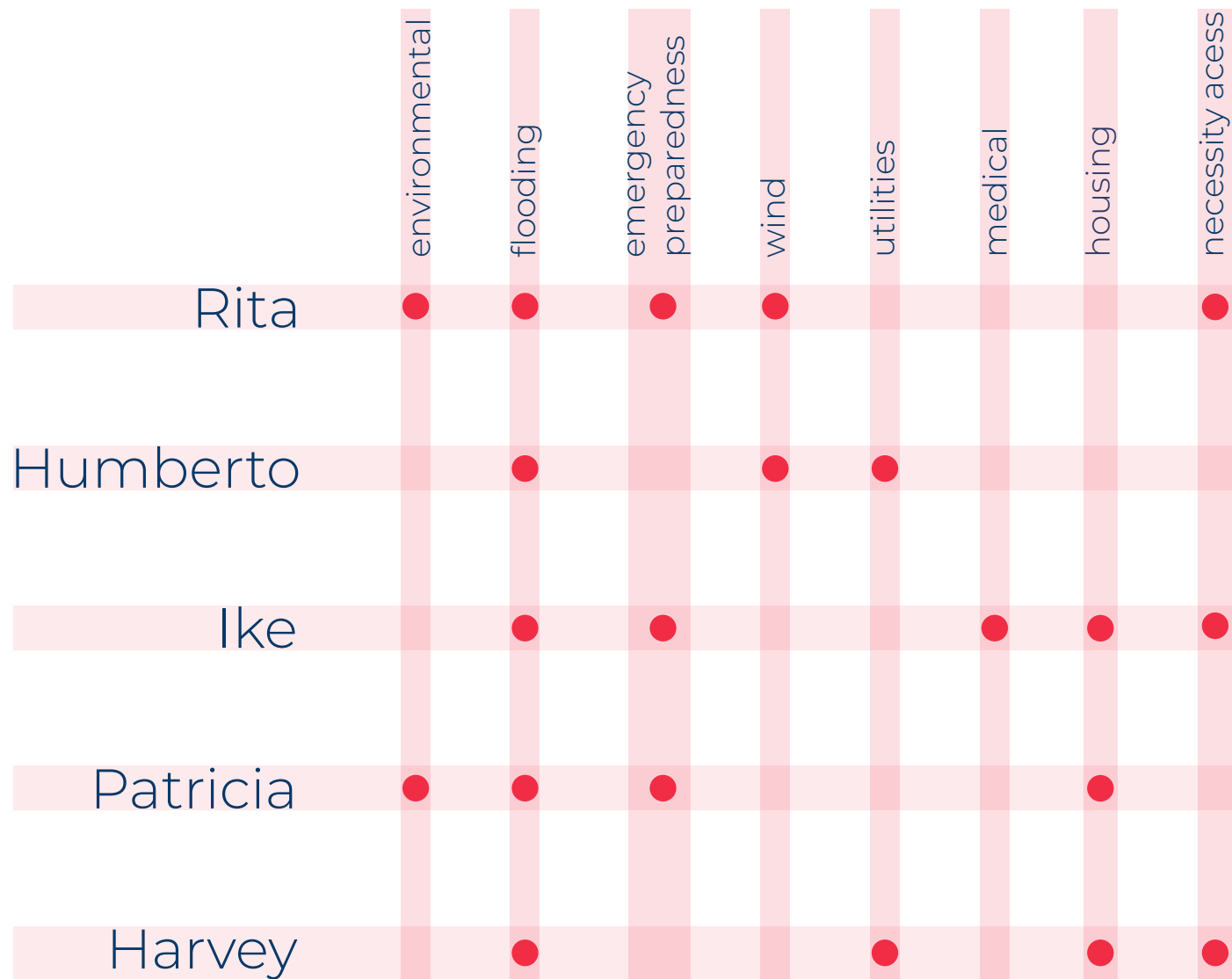

HURRICANE ANALYSIS

Looking through news articles over the last 5 hurricanes that impacted Texas, there has shown a deficiency in 9 different areas: environmental, flooding, emergency preparedness, wind, utilities, medical, housing, and access to necessities. Using the graph above to map out the extent of the needs in each aftermath, brought attention to flooding, emergency preparedness, housing, and access to necessities. All of these items can be remediated through the use of architecture and space. Acknowledging the deficiencies in hurricane preparedness, action can be brought forward in order to help mitigate and protect citizens before the next storm. Creating a facility that combines spaces that address the 4 most needed areas, can help start a conversation on what the best practice should be when planning a city for the future, with disaster mitigation in mind.

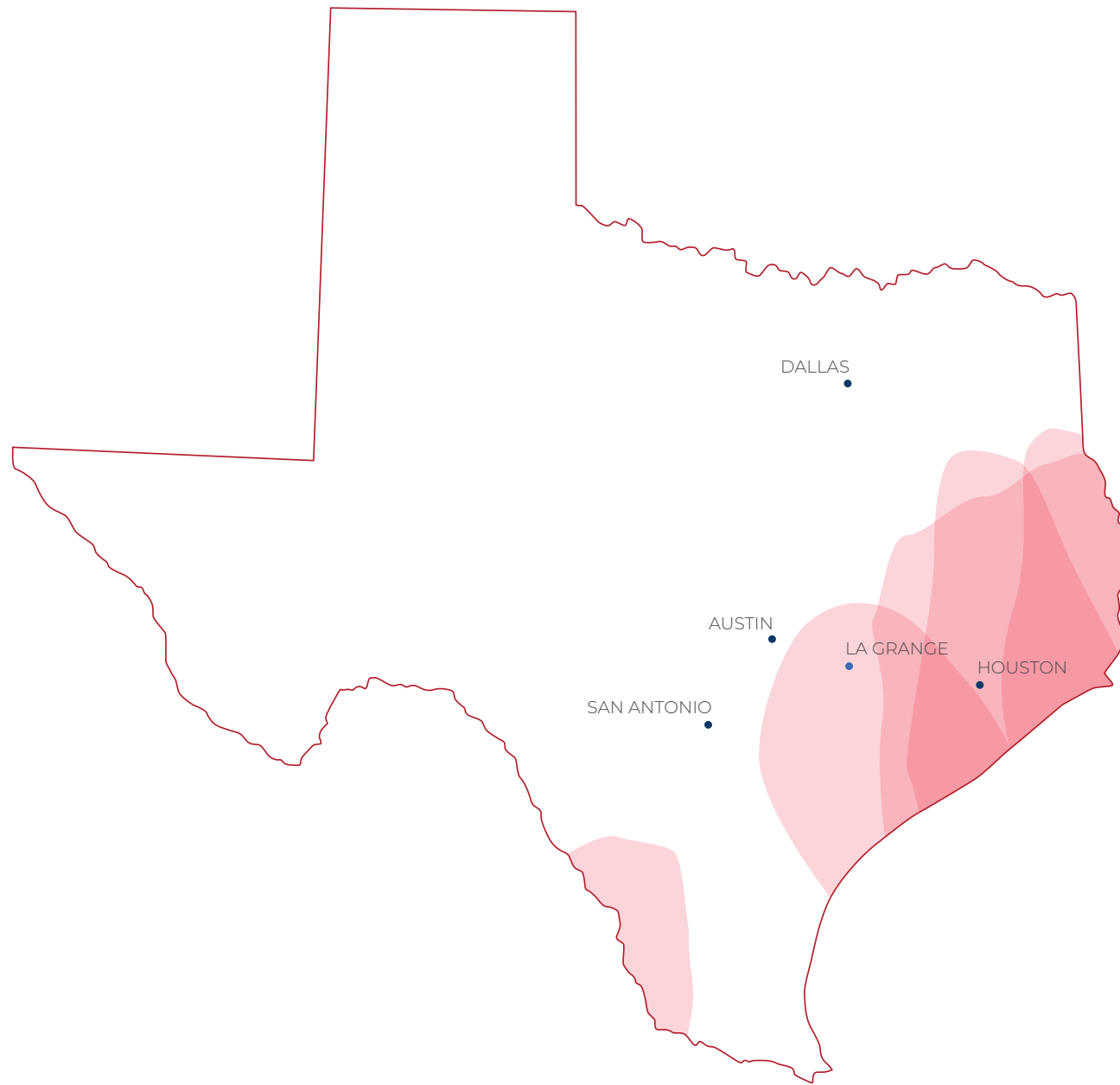

HURRICANE PATHS

The above map shows the paths of the past 5 hurricanes that have affected Texas. Analyzing this map can show just how widespread destruction can be, and how many communities are affected by storms. Rural towns are often in the path, but are usually forgotten in the aftermath when seeking or accessing support. La Grange, Texas is a small town located between two metropolitan cities, Austin and Houston. Being away from supporting services and being unprepared for the unprecedented height in flood waters, made La Grange a significant site to look into. Mainly focusing around how hurricane Harvey affected the whole town. As shown by the graphs on the right, there was a loss in population after the 2017 storm, along with significant damage to both public and residential buildings. Creating a facility with its main intent being to provide La Grange with a place of support, aids in ways to minimize collateral in times of disaster and implements a meaningful and useful complex integrating into the local community.

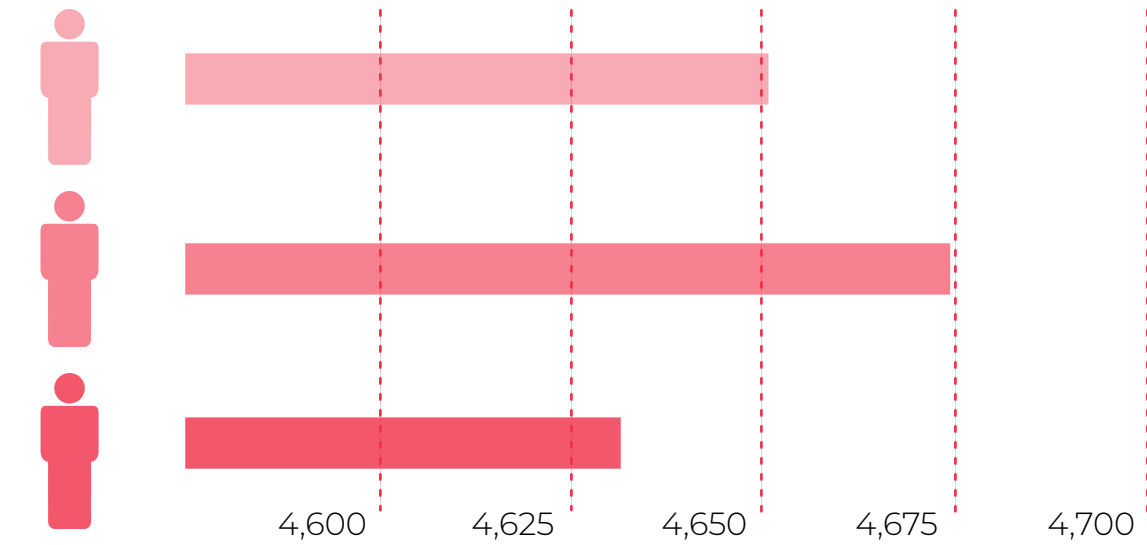

POPULATION

2016-4,651

2017-4,674

2018-4,632

42 PEOPLE GONE AFTER
HURRICANE HARVEY

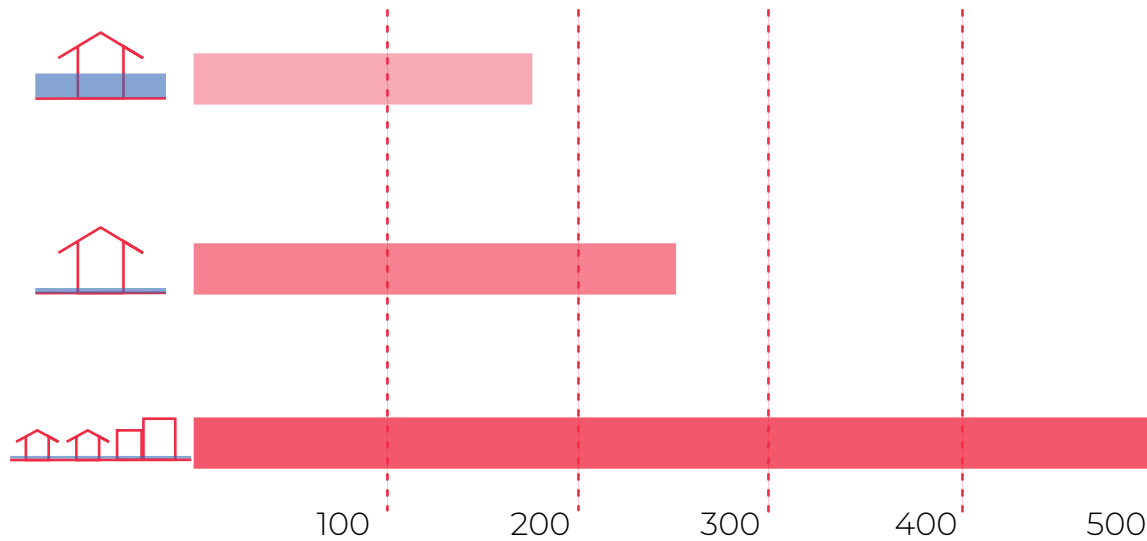

DAMAGE

HOMES DESTROYED - 175

HOMES FLOODED- 250

BUILDINGS FLOODED- 500

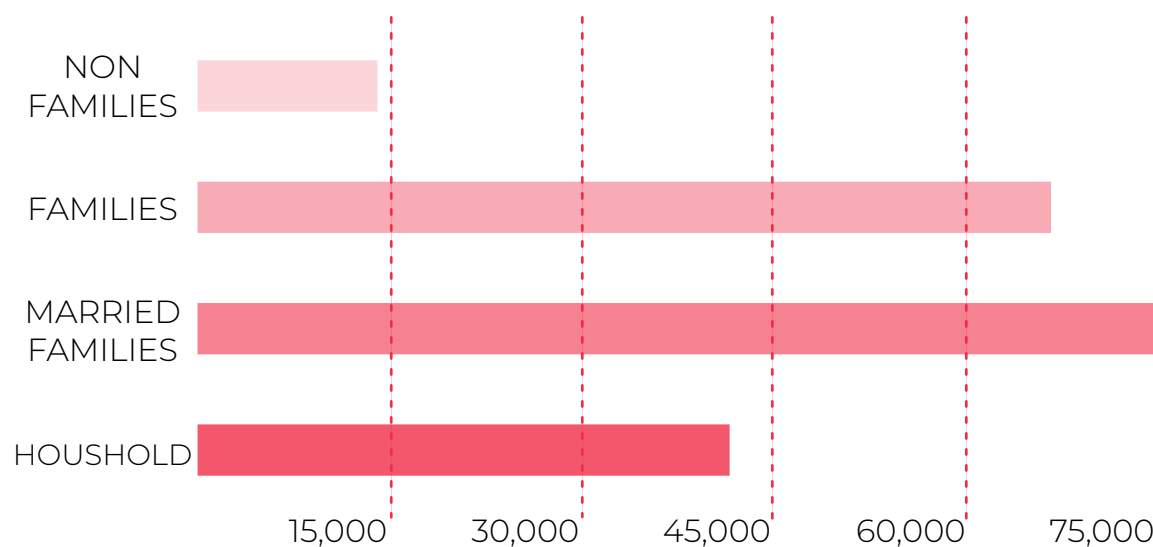

AVG. INCOME 2018

NON FAMILIES (NOT
RELATED)- \$14,324

FAMILIES- \$66,250

MARRIED FAMILIES- \$75,933

HOUSHOLD- \$41,768

“[WE] CALL ATTENTION TO THE NEED FOR A CLEARER UNDERSTANDING OF FLOODING IN TEXAS, FROM THE EVENTS THEMSELVES TO THE RESOURCES NEEDED TO MITIGATE THEM.”
-STATE FLOOD ASSESSMENT

SITE

02



The complex sits on what was once one city block. By evaluating La Grange's existing city grid, the site was divided into three blocks. These blocks were used to help integrate the new complex into the city. The resource center utilizes these areas to maximize the number of housing units, while still providing ample outdoor space that is crucial to preserve in a growing community. Using the open space and the complex housing to link the main facilities, allows a seamless transition from existing housing to community resources. Examining the surrounding architecture, the resource center is designed to flow into the existing neighborhood in an unobtrusive manner that compliments the blocks around it. The buildings employ a series of transitional elements in order to facilitate users integration into the site. The site also takes into account the complete architecture of the town, so that the complex also follows the town's typology patterns.



LOCAL TYPOLOGY 

La Grange is located in central Texas and features a variety of architecture. The design of the town draws inspiration from the existing city conditions, from the historic downtown decorated in brick and masonry to the gabled houses that are integrated into the landscape.

Using the above typology map to locate public spaces relative to residential, guided the design process and created principles to layout the different buildings within the complex. Utilizing the towns typology sequence as the guiding principles of the site plan, the complex's south eastern portion of the site houses the public buildings and open space. These act as a connector to the residential buildings, as well as create a sound barrier from the train that runs between the site and main street into town.



CITY GRID

The city of La Grange has a clear grid that was established for the town to grow around. This grid can be seen with dark blue lines in the figure above. When going through the town, there are smaller alleys that are highlighted in light pink. It is easy when looking at the town from a street view to see that these were not part of the original grid - dark blue. These smaller roads were created by the citizens, some of them not even being named.

The dark pink lines are shown to see where future roads could be made. These were the lines used to section the La Grange Community Center plot. By using the same logic that the town created, there can be a positive integration of the new complex.





SITE PLAN



50

“COMMUNITY SERVICES ARE WIDELY
ACCEPTED AS EFFECTIVE SOLUTIONS
TO SOCIAL AND ECONOMIC PROBLEMS”
- XU, GAO, AND YAN

ADMINISTRATION
CENTER

03



The administration building was designed to be the first stopping point in the complex for anybody unfamiliar with the site. The resource center was designed to be a multi use facility that enables the community to be actively engaged in recreation, learning, and enhancing relationships. Through the variety of spaces inside, the administration building can be used as a general gathering space, a space for local vendors, meeting based classrooms, as well as suite spaces all designed with multiple intentions. The entire site can be rented out for company retreats or family reunions one week, and used as a disaster resource center the next. By designing the administration building with a variety of spaces, it helps the users to envision just how many possible ways the entire complex can be put to use. The building utilizes transitional spaces that help users engage in the architecture in a variety of spaces.



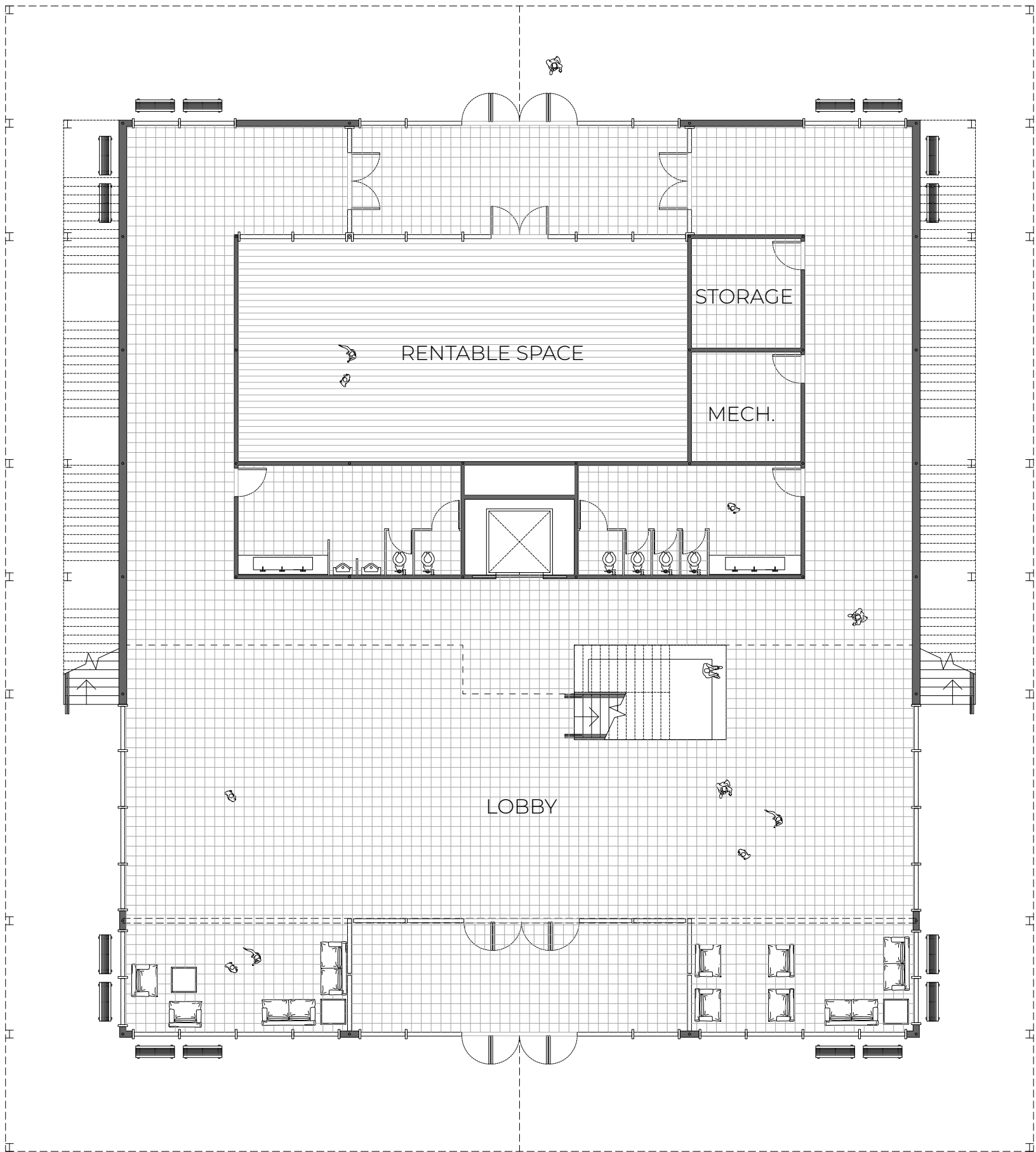

FIRST FLOOR PLAN



5

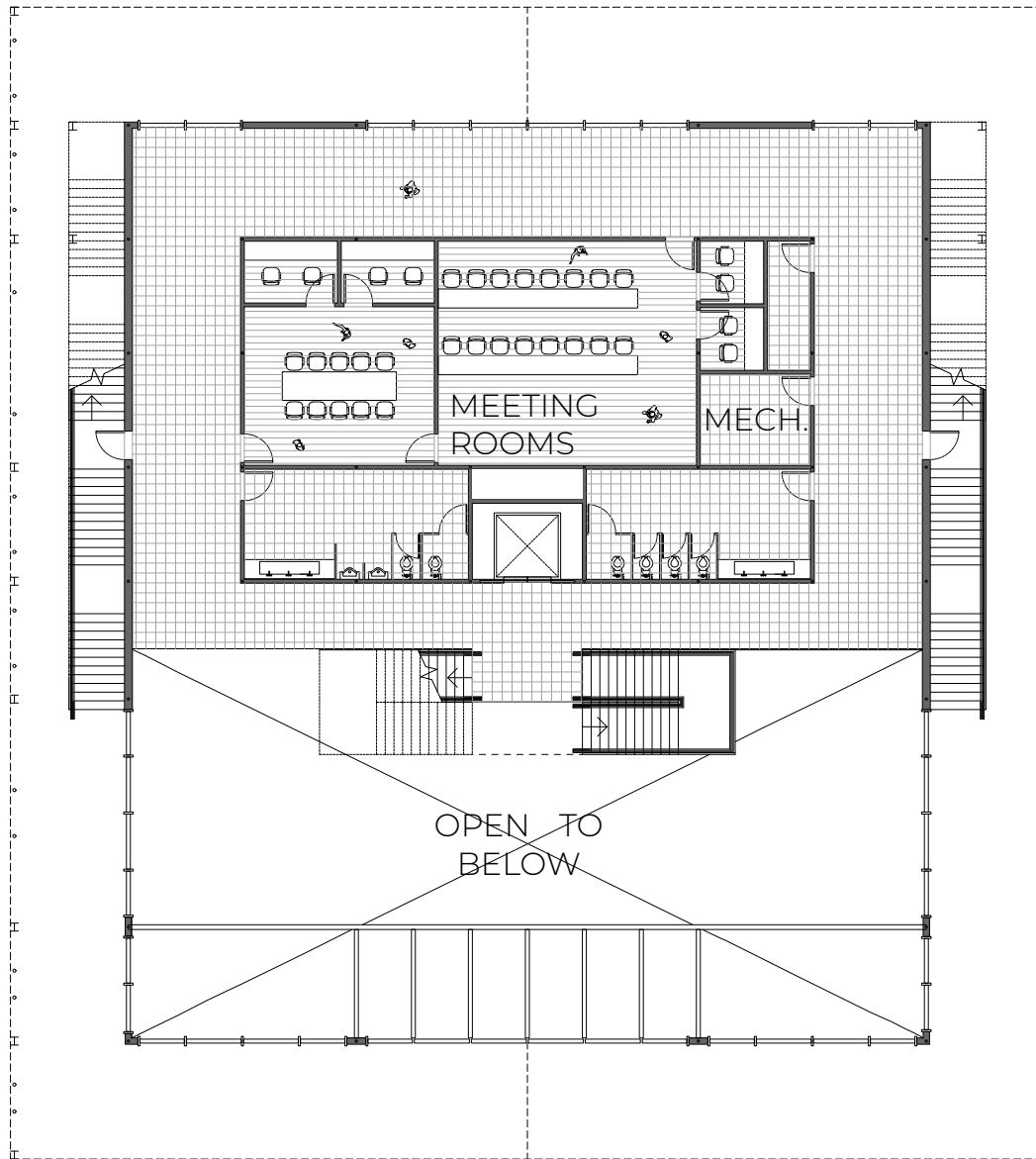

SECOND FLOOR PLAN



5

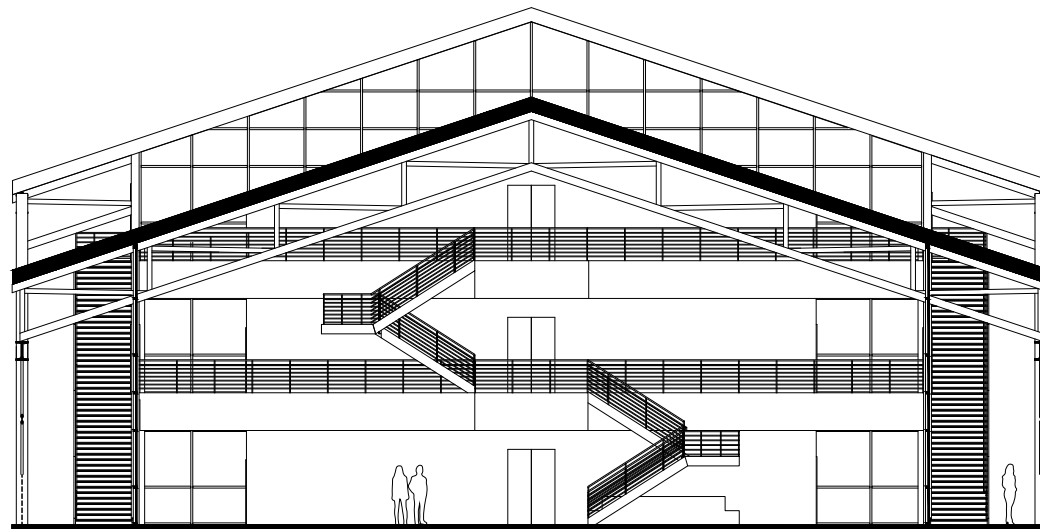

BUILDING SECTION

5

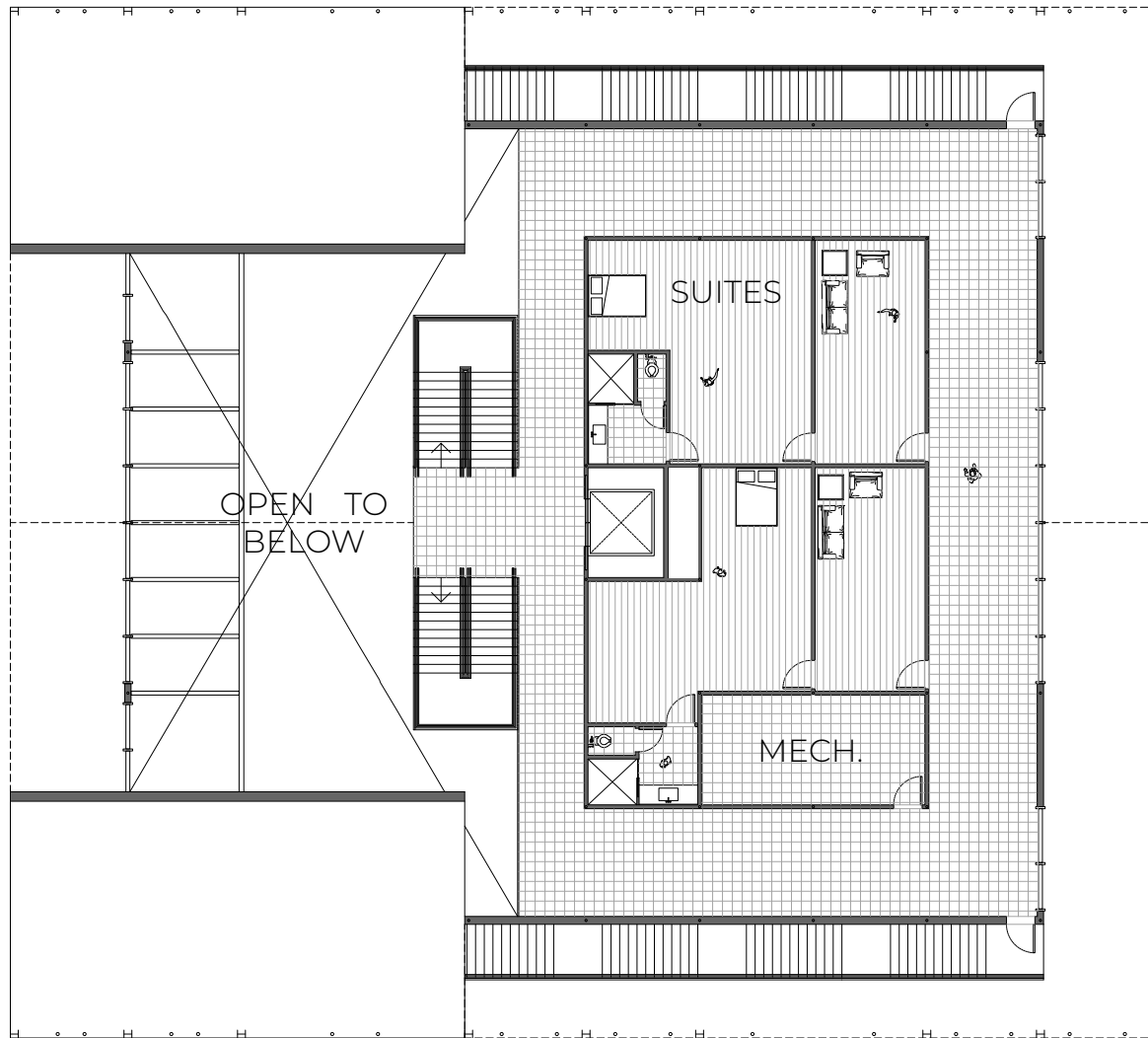

THIRD FLOOR PLAN



5

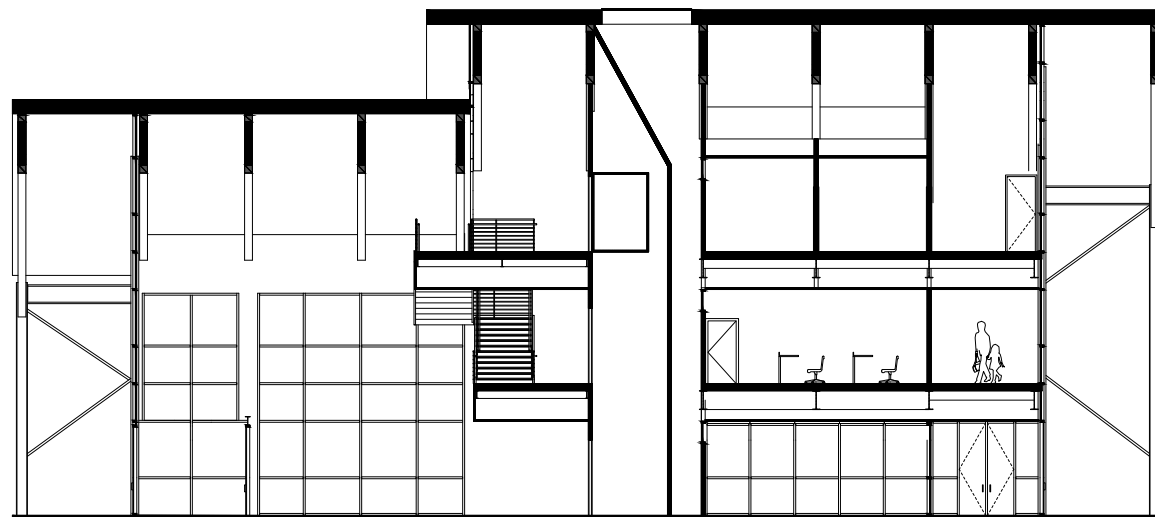

BUILDING SECTION

5

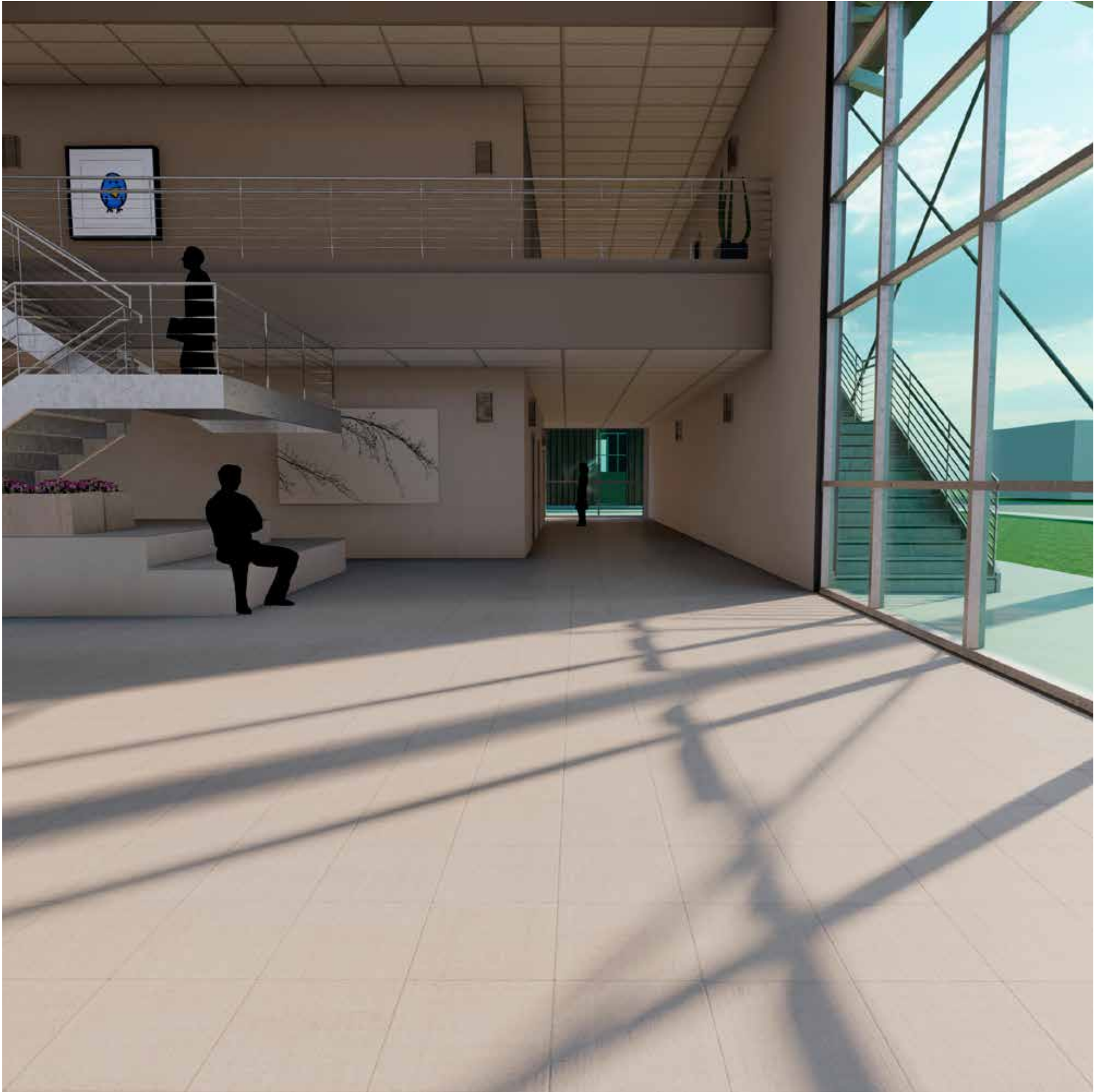

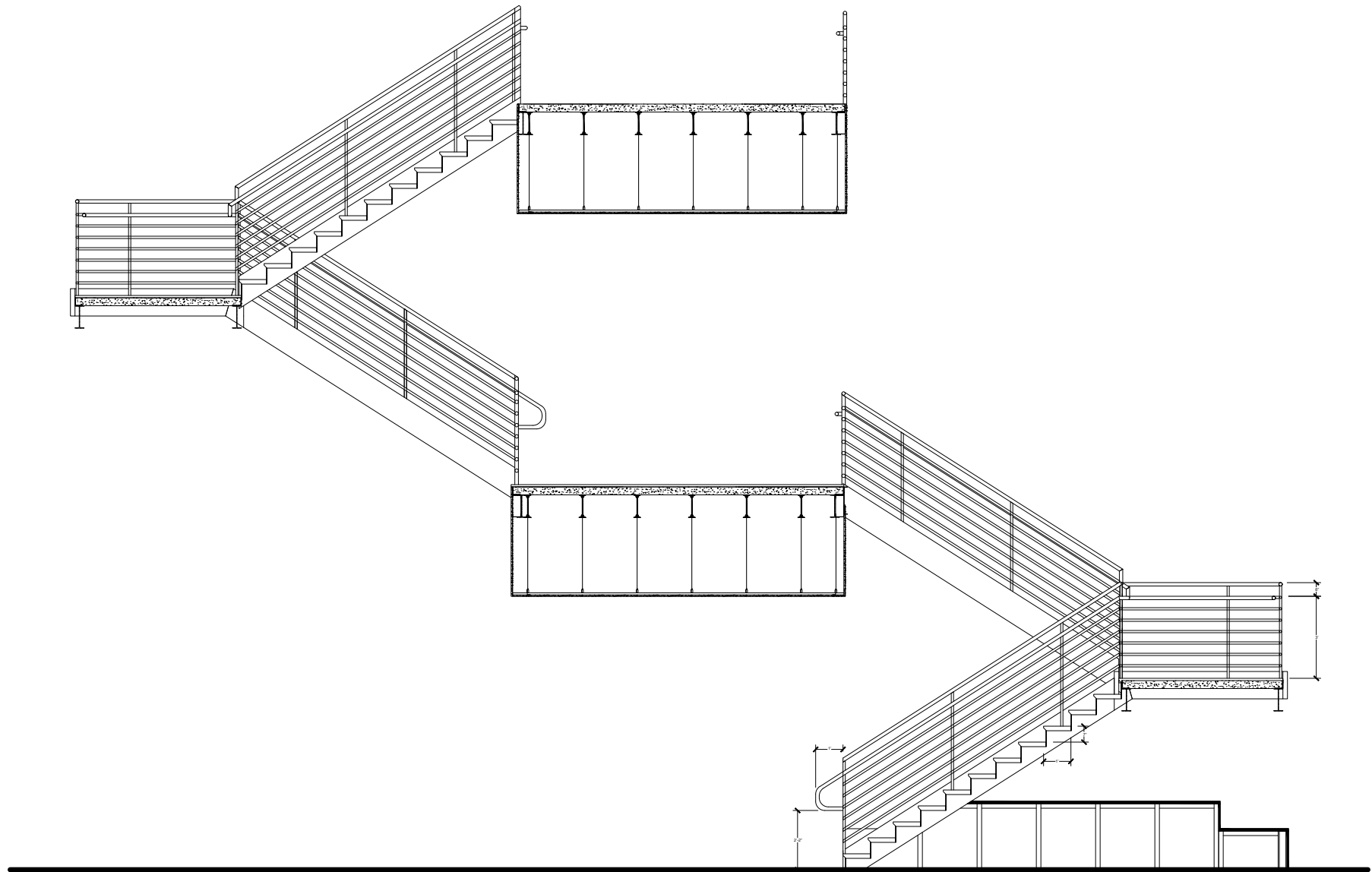

STAIR DETAIL

5

During a time of need, this facility can be used in another way. The large entry would be used as the first point of contact for people arriving on site. It is here where the first sources of information can be given.

Those that are in immediate need of help can be seen in the showcase space and assessed accordingly. While those who simply need more information, will be given instructions to go to the library where there are multiple types of spaces in which to get screened.

If a person were to arrive as part of the recovery team, they would be directed upstairs where a command center could be set up in the classrooms. These classrooms come in a variety of sizes in order to accommodate any size of breakouts that the team may need. If they are 24 hour staff, they can also use the suites set up on the third floor.

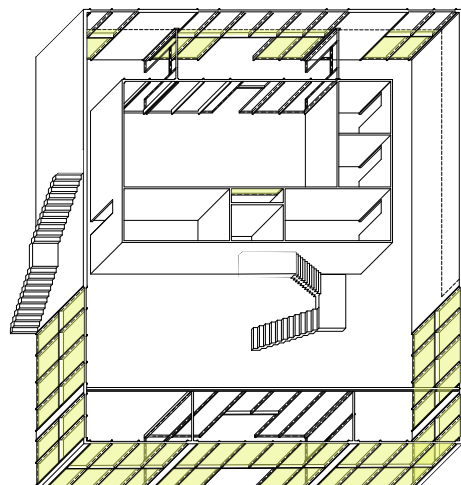
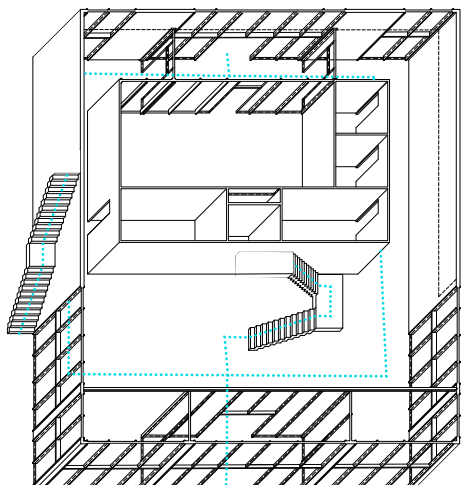
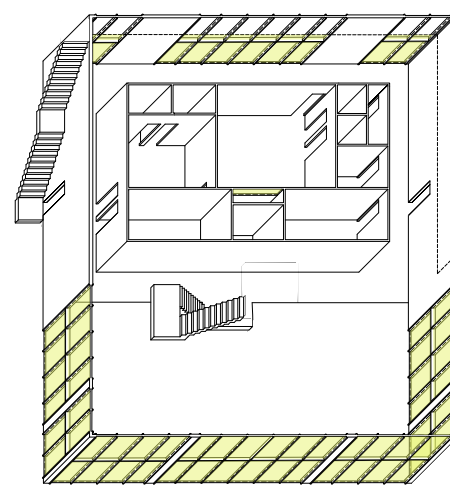
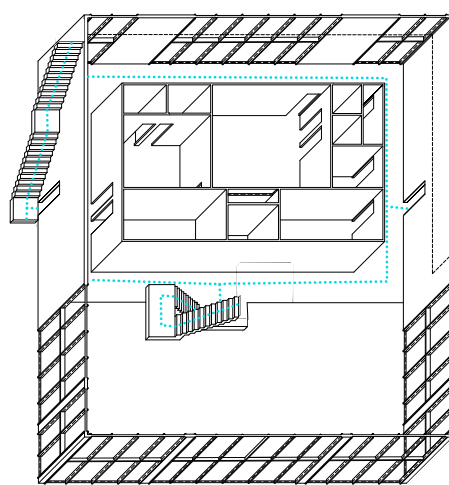
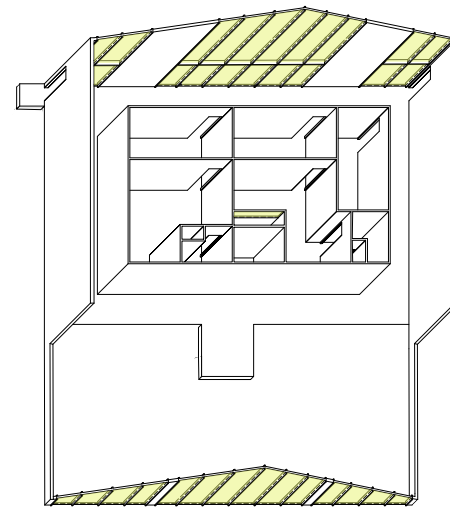
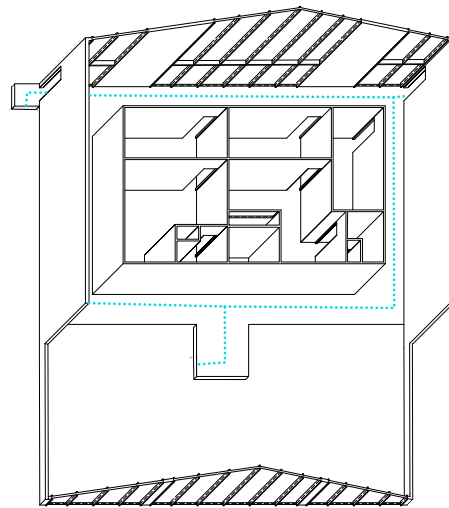

EXPLODED CIRCULATION DIAGRAM

EXPLODED DAYLIGHT DIAGRAM

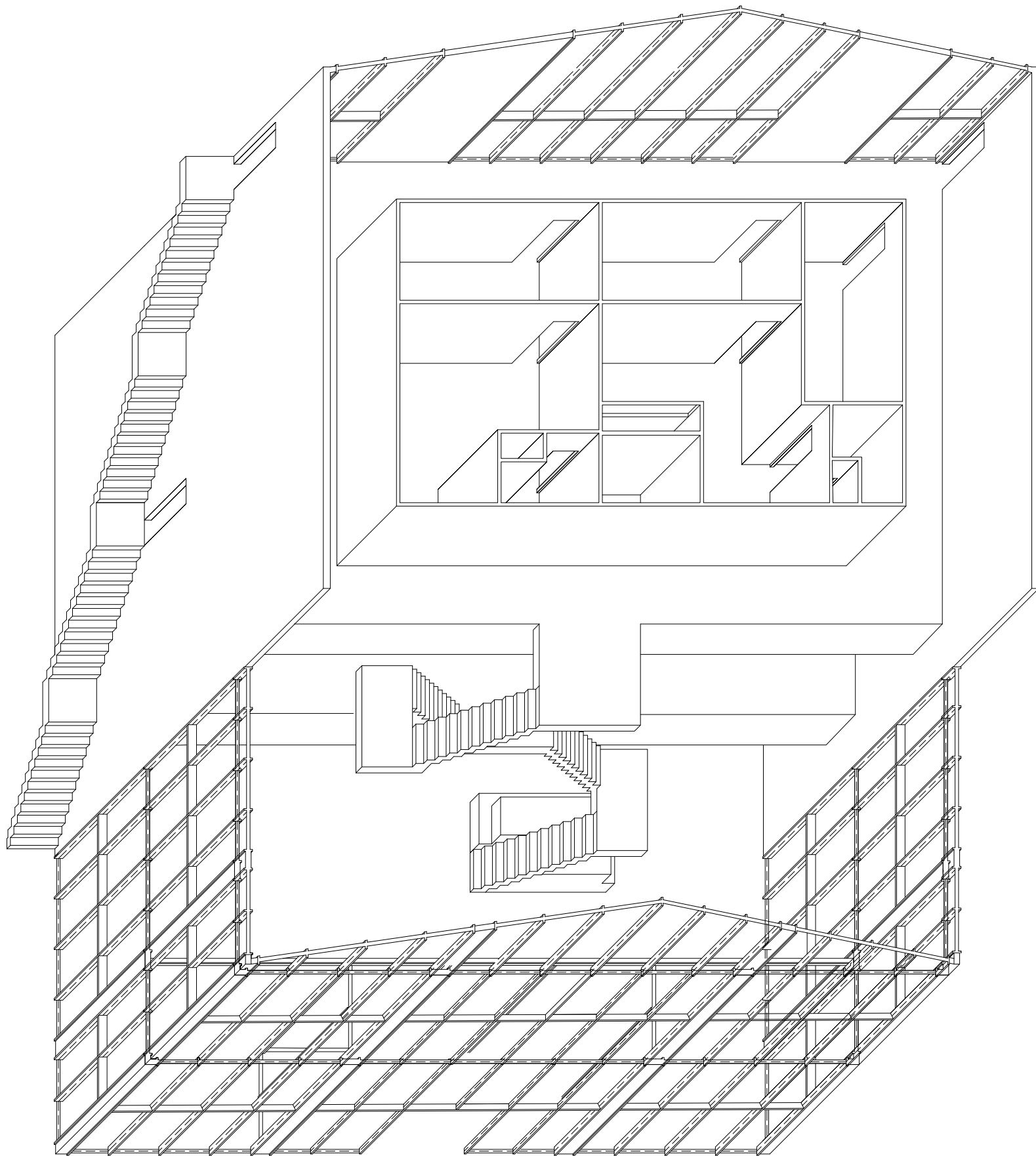

“[WE MUST] WORK TOGETHER TO BUILD, SUSTAIN AND IMPROVE OUR CAPABILITY TO PREPARE FOR, PROTECT AGAINST, RESPOND TO, RECOVER FROM AND MITIGATE”-FEMA

LIBRARY

04



The library is a space where the community has the opportunity to come together in any way that they might need to. It serves as a link between the complex and the people that it helps. Upon entry into the main space, a visitor is welcomed by a large, bright and open lobby. This lobby links the two wings of the building. Each wing houses a variety of spaces so that each occupant can choose the types of space that they wish to be in. From the large lobby to individual nooks, every member of the community that enters the library will find a space that they feel comfortable in and can immerse themselves in learning. Each occupiable space has been designed to have access to natural daylight, which is crucial when promoting a learning environment. Community members can actively engage in their environment by traveling throughout the building using the ramps that were developed around raised platforms, and depressed spaces that can be used as necessary.



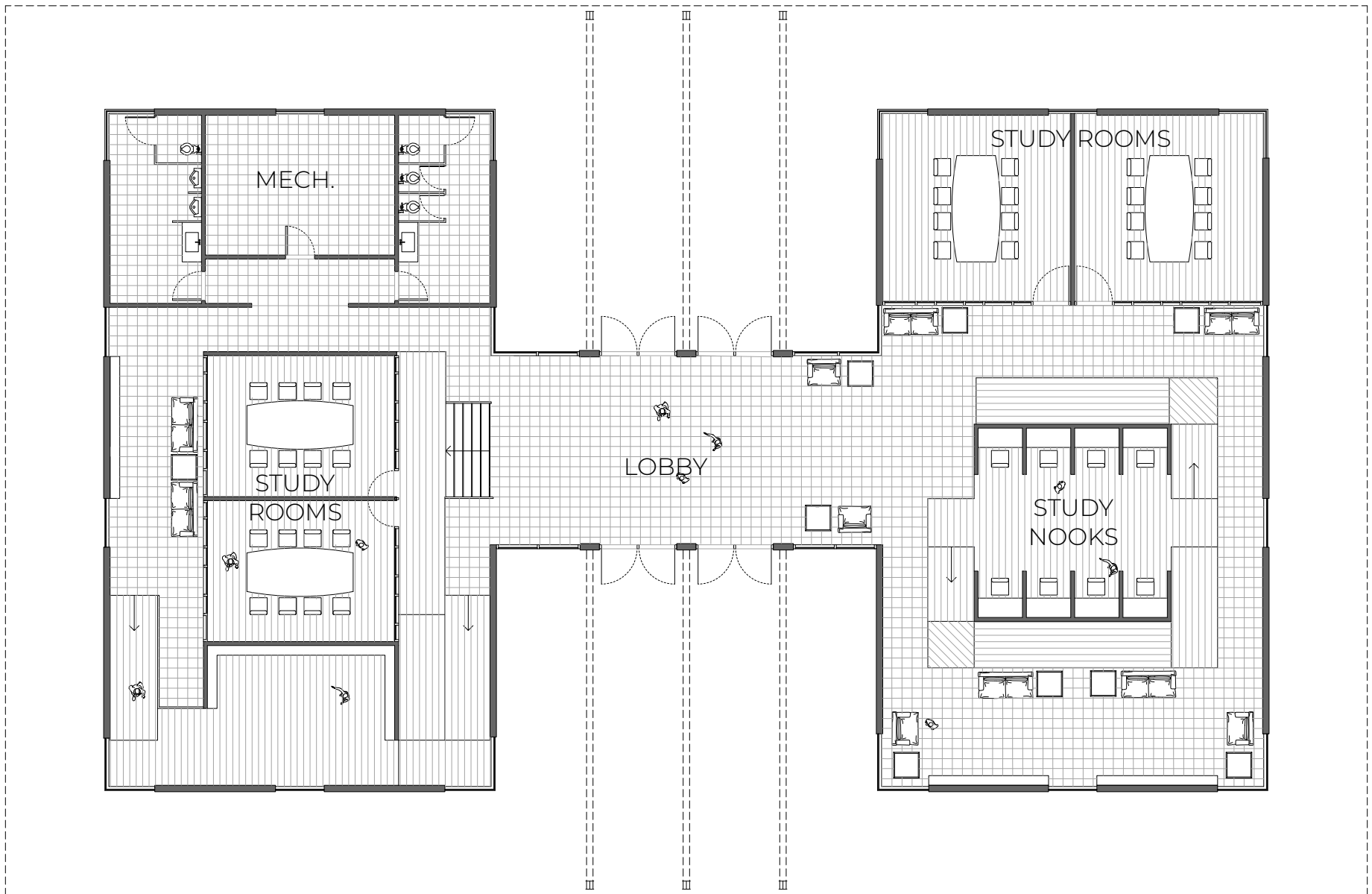

FLOOR PLAN



5

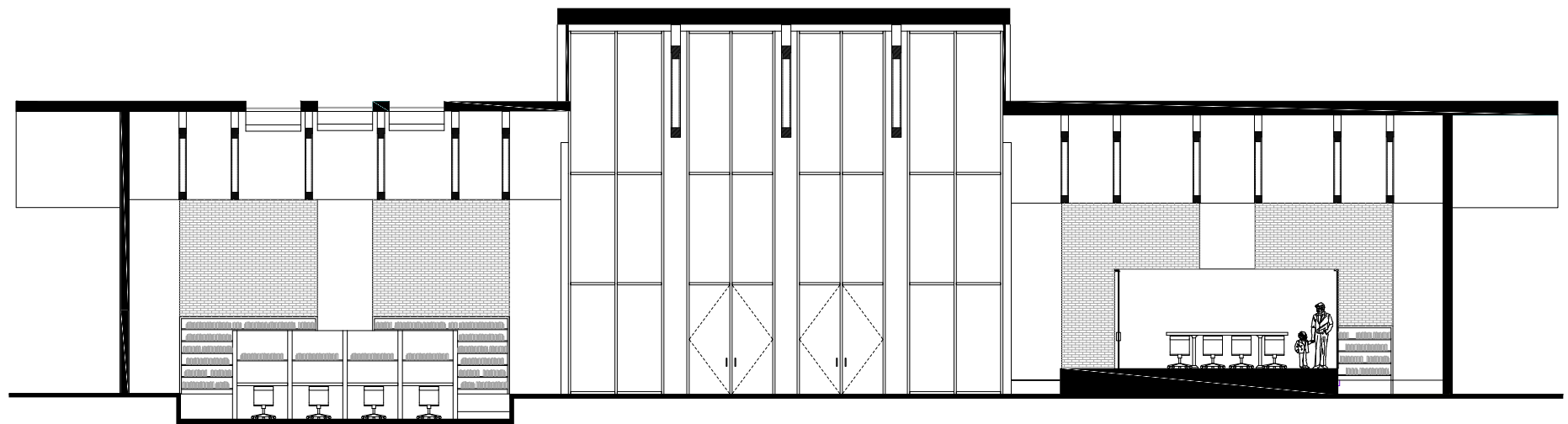

BUILDING SECTION

5

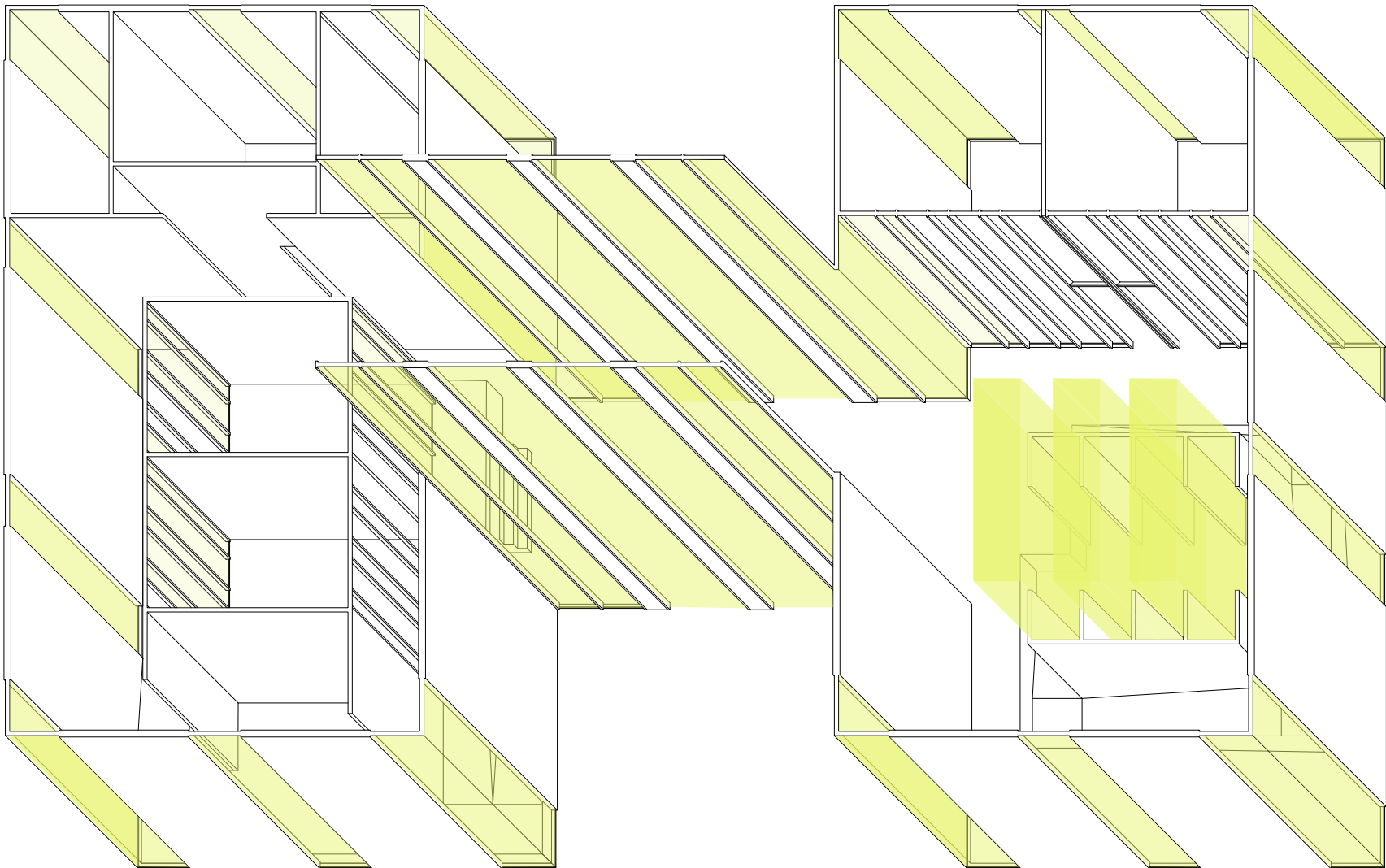

NATURAL DAYLIGHT DIAGRAM

The daylighting diagram above was done to showcase the amount of natural light that can enter every occupiable space, and show the variety of volumes within the building. Each classroom is designed to hold small groups of people and create a sense of privacy, while still being engaged with the buildings architecture.

In times of need, this facility can be used to hold one on one screenings and small group lessons in a comfortable environment. Whether a person is in need of a place to stay or simply here for more information, there is a space in which they can access what they need facilitated through architecture.

WALL DETAIL REFERENCE LIST

1. PREFABRICATED METAL ROOF PANEL
2. PURLIN
3. PREFABRICATED METAL ROOF EAVE
4. METAL CEILING PANEL
5. INSULATION
6. VERTICAL SIDING
7. RIGID INSULATION
8. SHEATHING
9. 6" METAL STUDS
10. INSULATION
11. BACKERBOARD
12. THIN BRICK VANEER
13. METAL STUD BRACING
14. BASE RUNNER- 15. FLASHING
- 16. L BARS
- 17. REBAR
- 18. STIRUPS
- 19. BOX FORMS
- 20. WATER PROOF MEMBRANE
- 21. SOIL RETAINING BOARD
- 22. TOP FRAME
- 23. SAFETY GLASS
- 24. FLOOR PANELS
- 25. RAISED FLOOR STRINGER
- 26. BASE FRAME
- 27. GYPSUM BOARD
- 28. METAL STUD
- 29. RAISED FLOOR PANEL

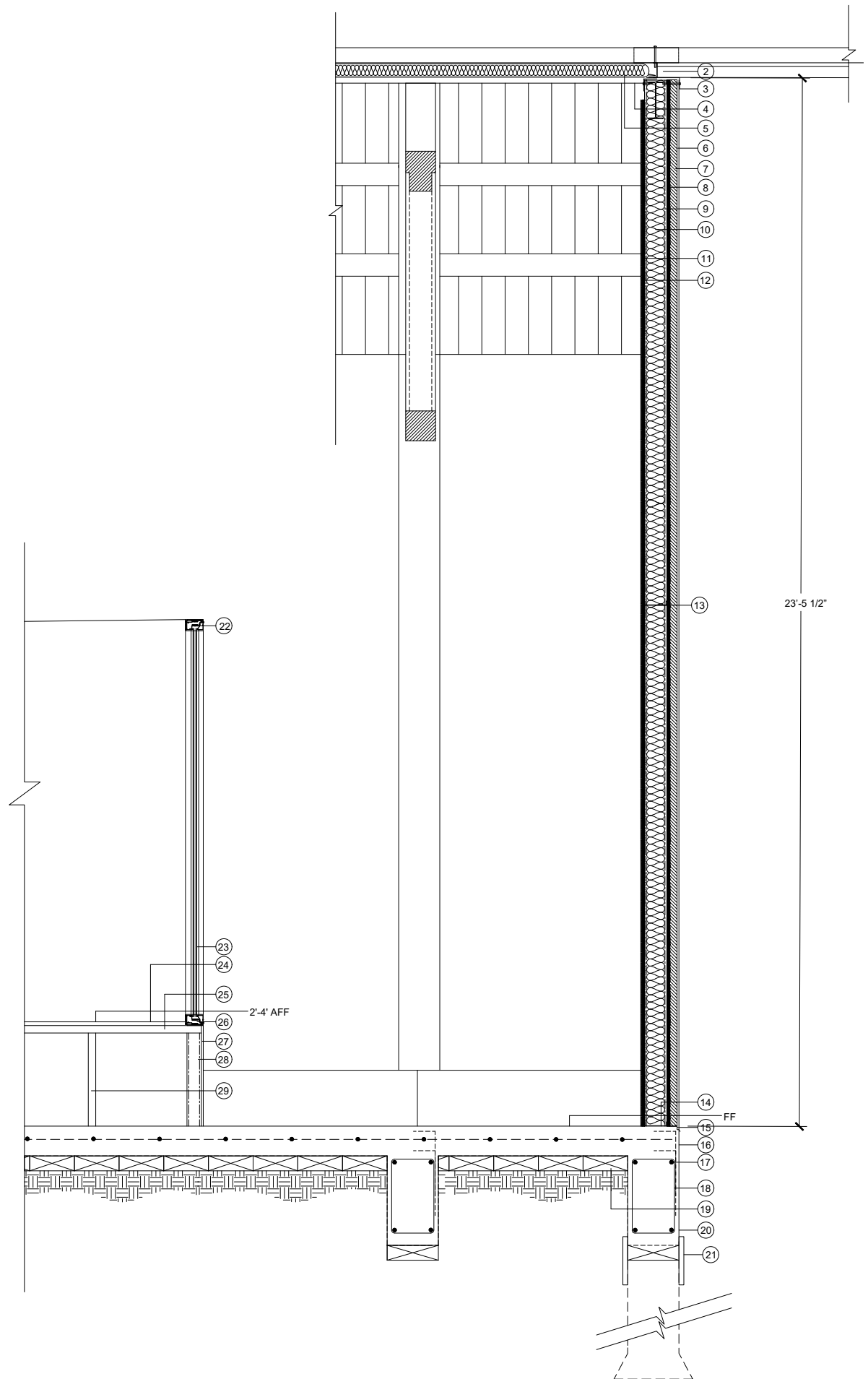

“SHELTERS MUST PROVIDE A SAFE AND SECURE ENVIRONMENT THAT ACCOMMODATES THE BROADEST RANGE OF NEEDS IN OUR COMMUNITIES”- RED CROSS

RECREATION
CENTER

05



The recreation center is a key factor in the complex as both a community gathering point and as a disaster resource. The purpose of this facility is to have a safe space that has the capability to serve its users. The public gym and on site dining facility can be easily converted into a shelter to facilitate the demands of disaster relief. The large lobby is sectioned off for check ins and rentals, with interior courtyards bringing natural light into the middle of the building. This also serves to divide the dining facilities and the gym. This building, along with the others, is meant to create a sense of safety for each and every one of its users. The kitchen has ample storage for both cold and dry goods to serve many. By placing the rec center in the central portion of the site it serves to connect the housing units as well as the other public spaces. Designing open and thoughtful spaces through architecture can help facilitate a sense of well being.

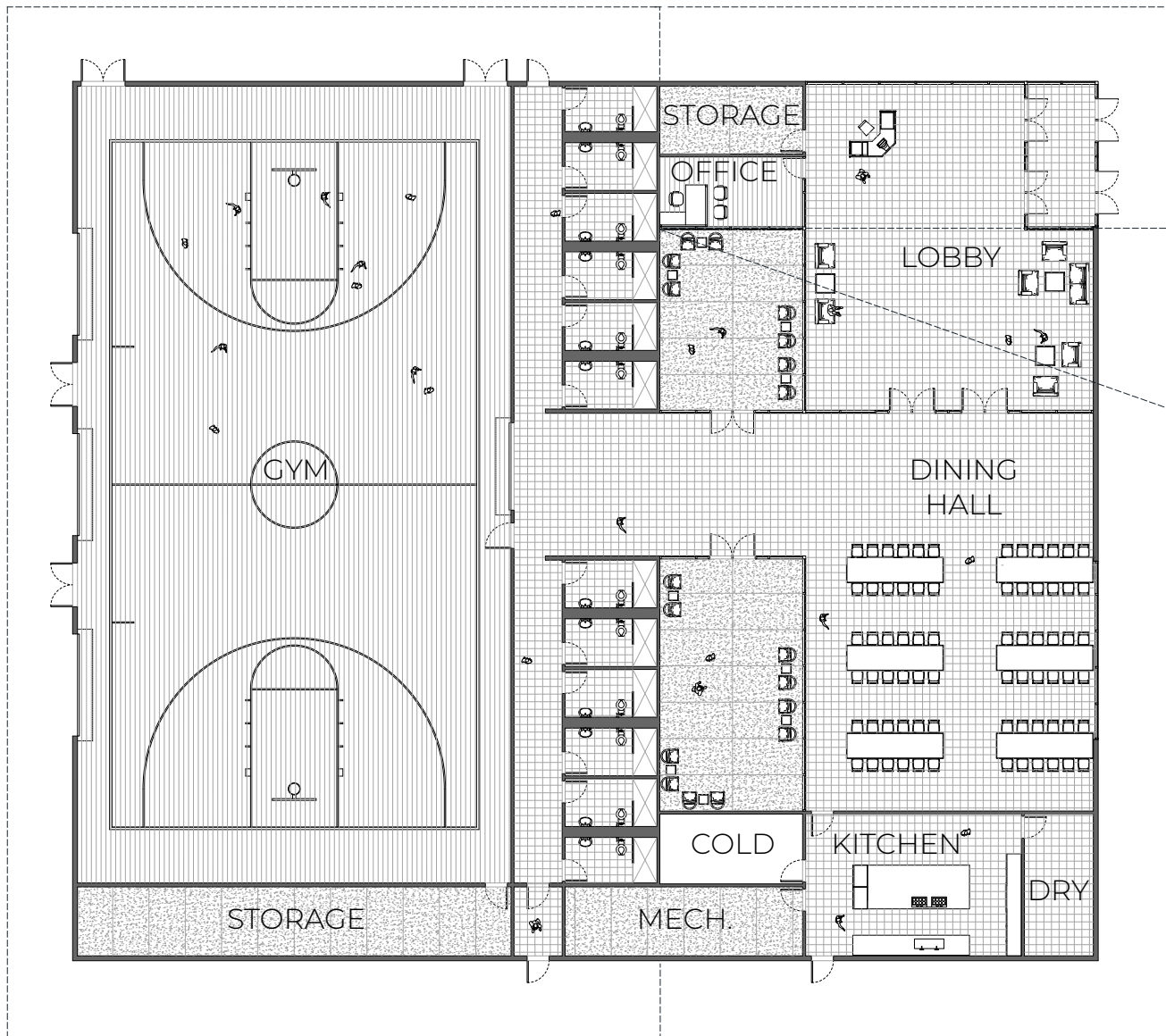

FLOOR PLAN



5

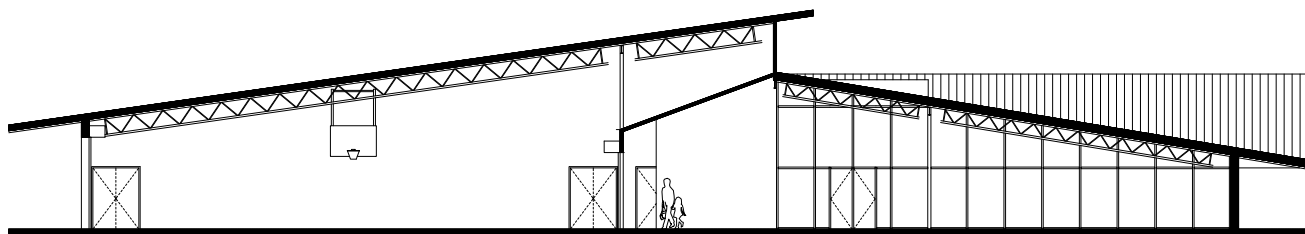

BUILDING SECTION

5

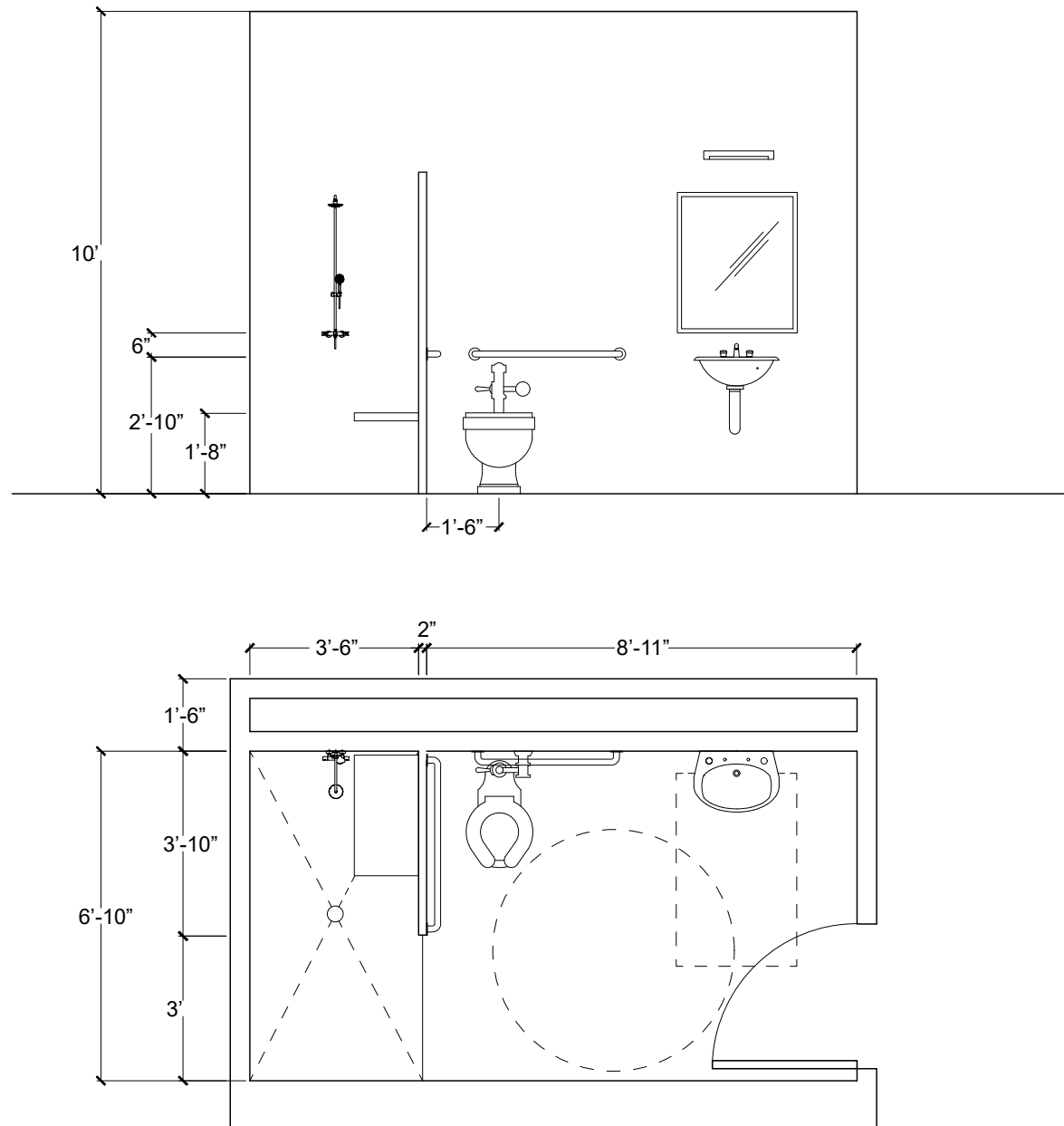

BATHROOM DETAILS

The recreation center was created with the intent to have versatile spaces that can be used in any situation depending on the users needs. Whether that be a young couple in search of a wedding venue with access to the outdoors, a large kitchen and dining space, and on site renting for friends and family, or members from the neighborhood coming to play a pickup game of basketball. With the idea of it being both a fun and relaxing space, the program of the building became one that needed to be flexible to provide the users with a sense of personalization. In order to facilitate this through architecture, the spaces are large and filled with natural light so that they seem even bigger and full of possibilities. Keeping versatility in mind, there were the additions of the interior courtyards. These were added for people to have access to nature, even on rainy days. This will provide an “outdoor” area that can be enjoyed as a getaway from a large dining party or a volleyball tournament, while still being able to feel a part of the whole space.

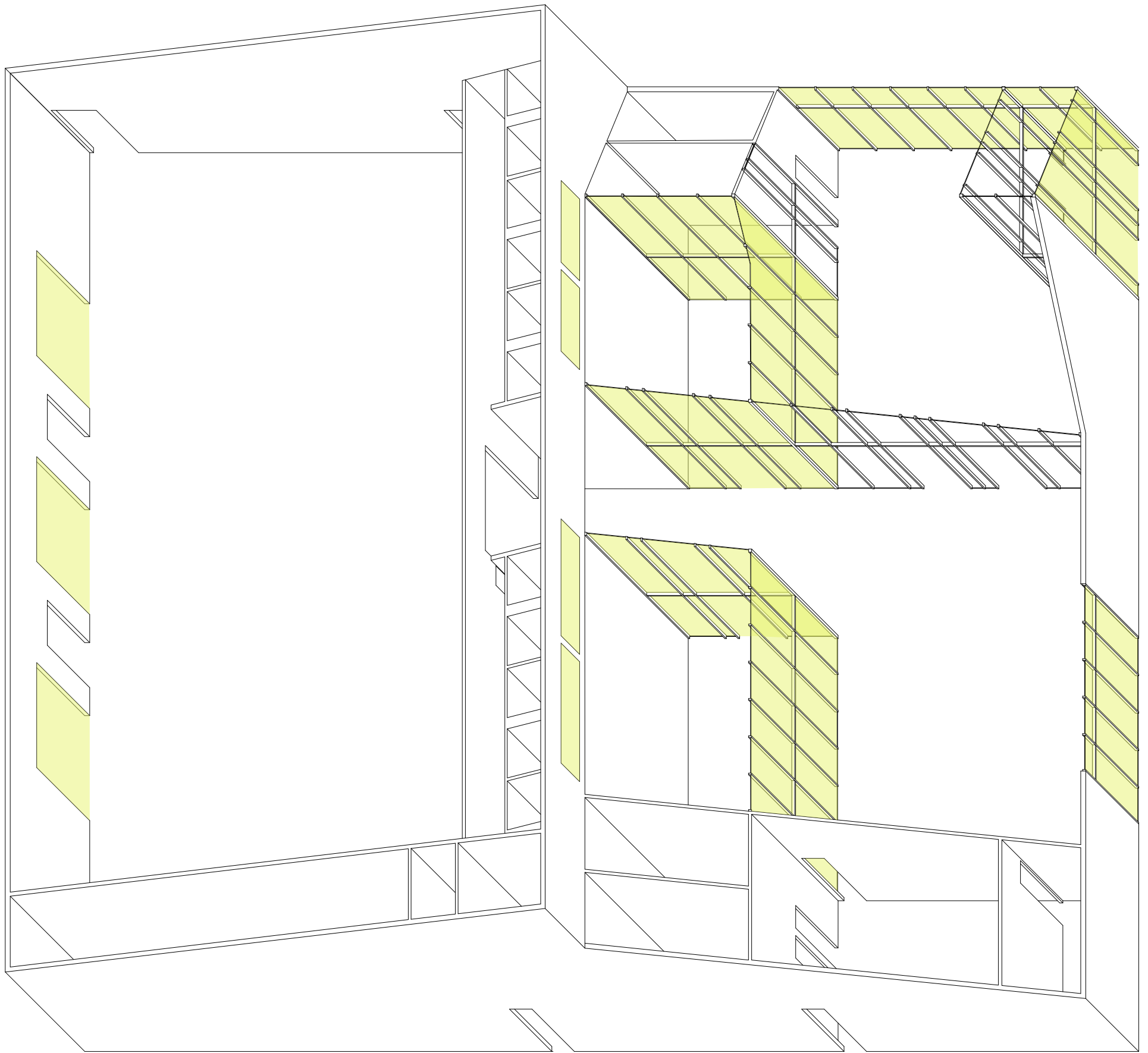

DAYLIGHTING DIAGRAM

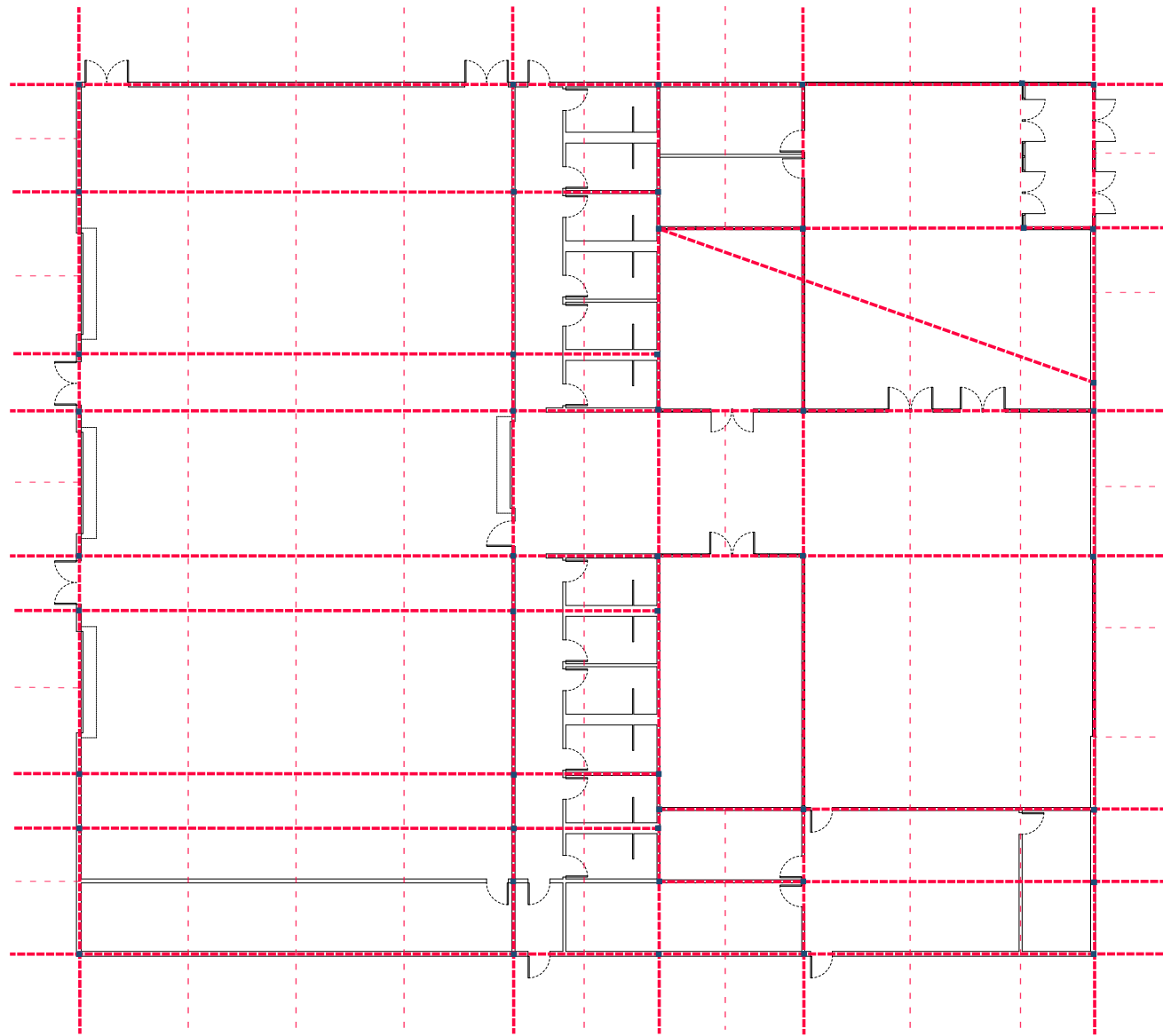

BEAM LAYOUT



5

In times of disaster, the recreation center would then be able to convert into a space for temporary cots and meal preparation. The lobby, being alongside the administration building and the library, would serve as the check in point for any member that should need a place to stay. Having the entry along one of the roads that runs through the site, allows for emergency response vehicles to cut off the road. This will be key for them to pass out food and water, laundry stations, and other services that the community might need in times of distress. Along the south side of the main road, is ample storage space that can be used to house donations or field deliveries. While on the West side of the building, there are overhead rolling doors that can be opened to allow the open field and the interior gym to flow into one another. This will promote activity for the members of the community to enjoy.



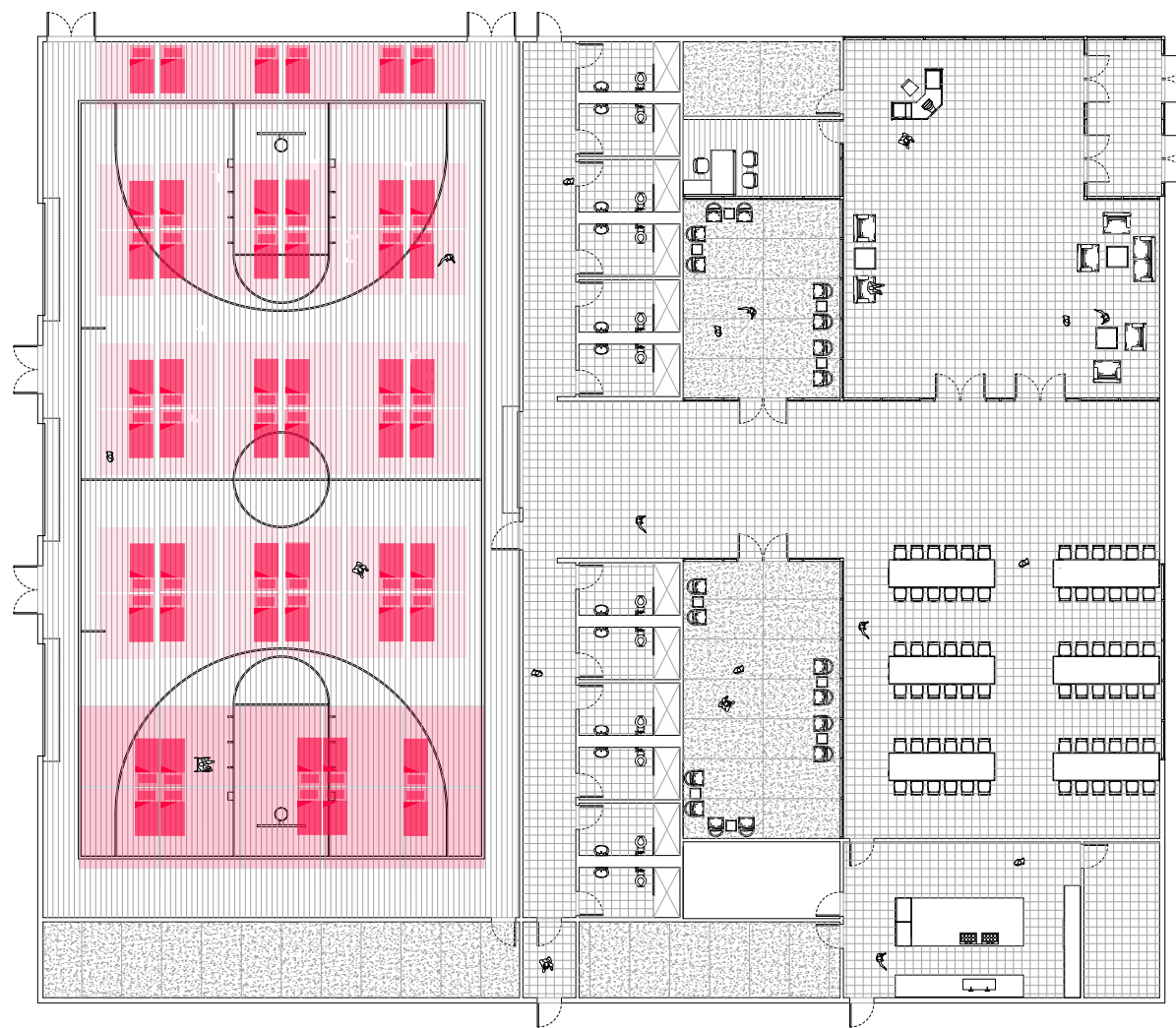

COT LAYOUT



5

Designing the building with the intent to house emergency living space, the gym became the main focus on how to better serve those who would live there for a short period of time. Currently, the Red Cross is the only organization of any kind that is able to certify a space as a shelter. Their rules became the guidelines for how much space was to be allotted in each area. Looking at the population loss between the years surrounding Hurricane Harvey, it was established that an occupancy load of 50 was the design factor in which each space centered around. After establishing that number, the rest of the building began to form. From the large lobby to a dining facility able to handle an influx of people. Overall, the gym can house 52 cots with ample space for circulation, with additional space for 7 cots in the lobby if there is ever the need. In addition to the space allotted for dining and cots, there are also single occupant ADA compliant bathrooms to provide privacy and safety for each user. The recreation center becomes the central role in disaster mitigation by providing necessary shelter when a community is facing adverse times in the wakes of disaster.

“IT IS CRITICAL TO DESIGN THE SPACE
NEAR ONE’S HOME IN RESPONSE
TO ONE’S IDIOSYNCRATIC NEEDS”-
RANDOLPH HESTER

CHAPEL

06



An essential part of any community is a space dedicated to outdoor gathering. Adjoining the residents and open space of the site is where the outdoor pavilion, dubbed “The Chapel”, was placed. It was designed as a congregating space surrounded by nature with varying degrees of privacy. The main space under the gable roof is flanked on the East and West by aisles, in which smaller groups can come together and still be under the same roof and part of the larger volume of that area. As versatility being the guiding principle in all of the buildings, this building was designed with the idea that any activity that involves gathering can take place here. This could be anything from a child’s birthday to an outdoor service area, in the event that one of the churches in town has to shut its doors due to flood damage. The chapel serves as a showcase of just how resourceful the entire complex can be with imagination and volition.



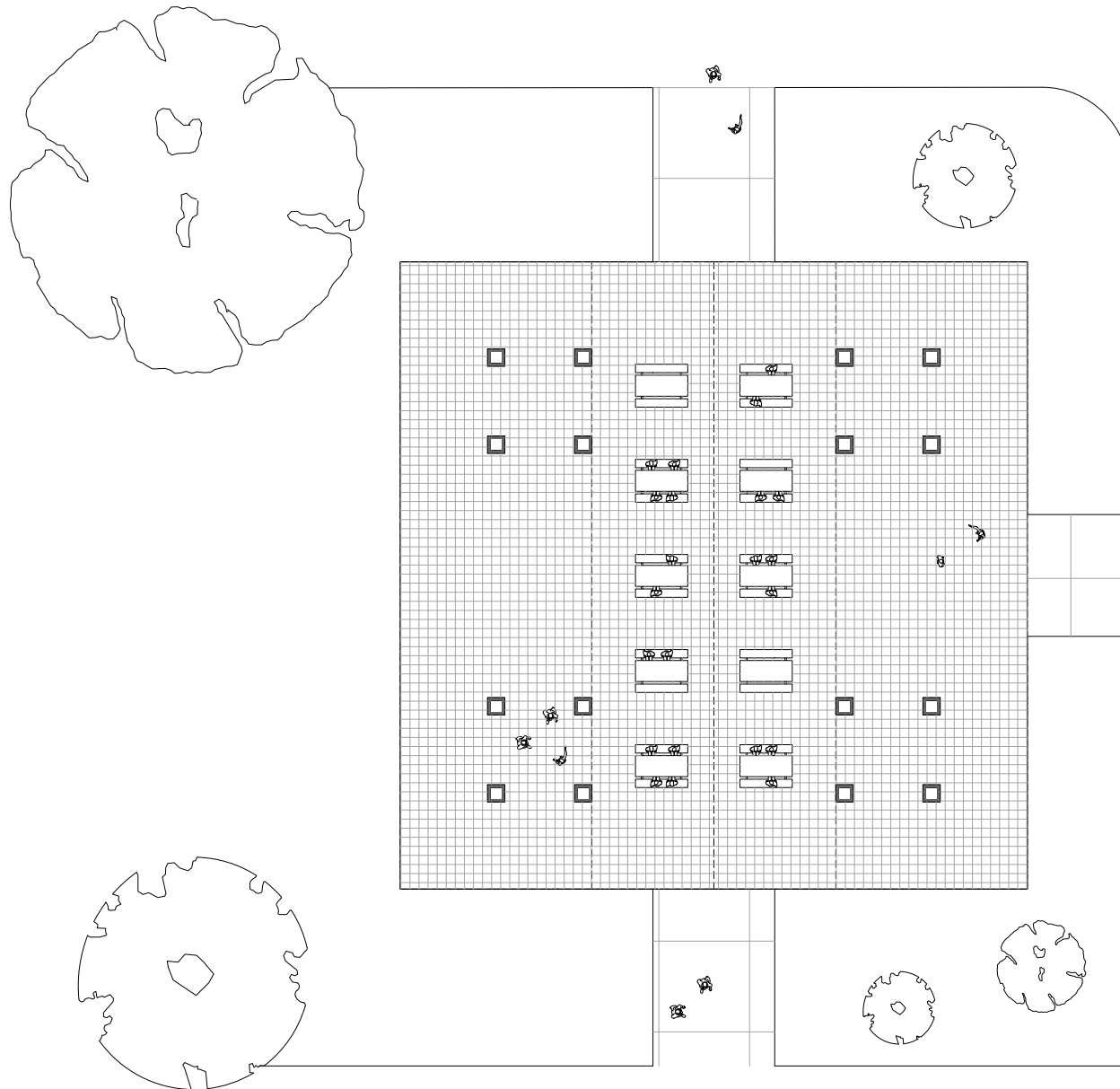

FLOOR PLAN



5

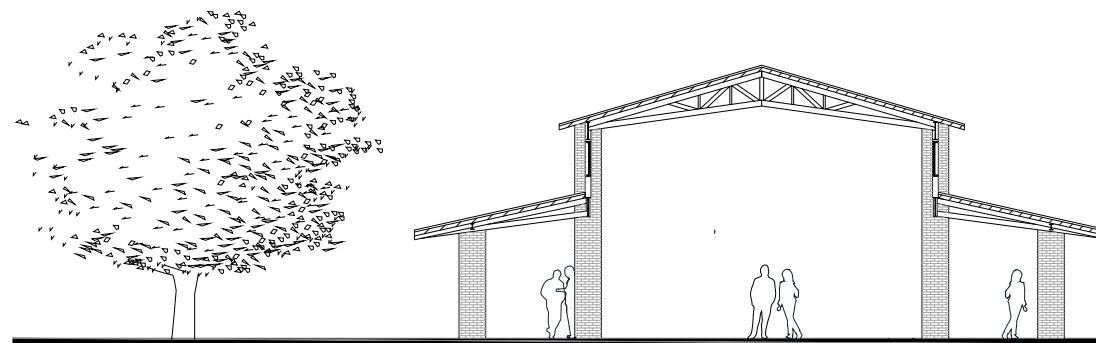

SECTION

5

“IT IS ESSENTIAL FOR US TO BE PREPARRED TO CARRY OUT THE INITIAL EMERGENCY RESPONSE ON AN INDEPENDANT BASIS”- FAYETTE COUNTY EMERGENCY PLAN

HOUSING

07



One of the main functions of the complex is to provide a place for emergency housing readily available for the community. In the wake of flooding many people often suffer from lack of housing and do not always have the insurance needed to get rebuild or the ability to have temporary housing with a friend or relative. This complex would be a space of already available housing units for members of the community in need of temporary shelters. They also enables the center to rent out the complex as a whole to large groups of people. The houses are available in three different sizes, from an occupancy of two to an occupancy of six. Supplying the complex with housing it also aids in the integration of the resource center as a whole into the existing neighborhood. Placing the housing on the outer perimeter and creating a dialog between housing units and community center it develops a space for all members of the people to come together.

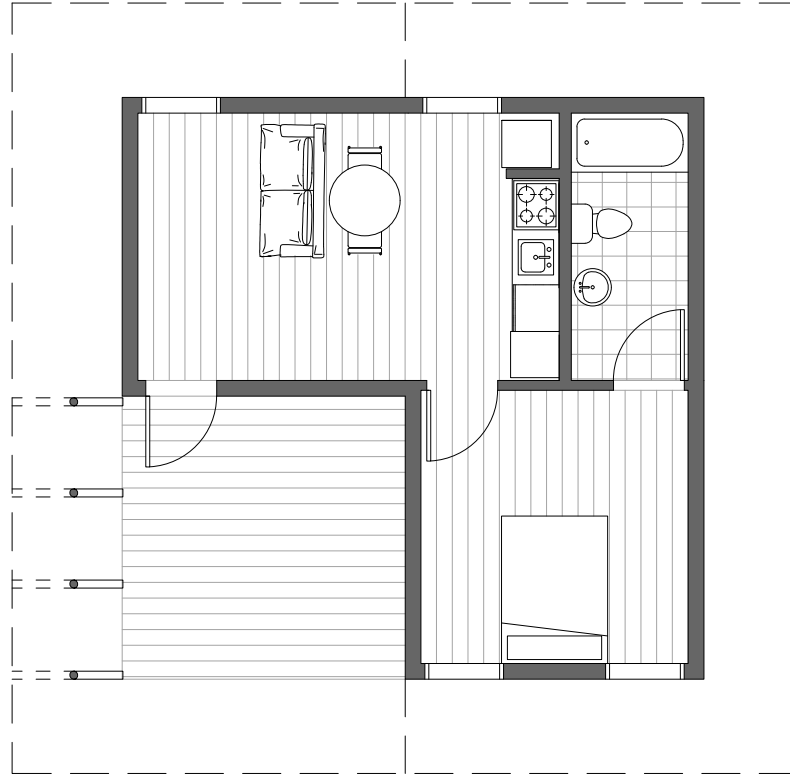

FLOOR PLAN

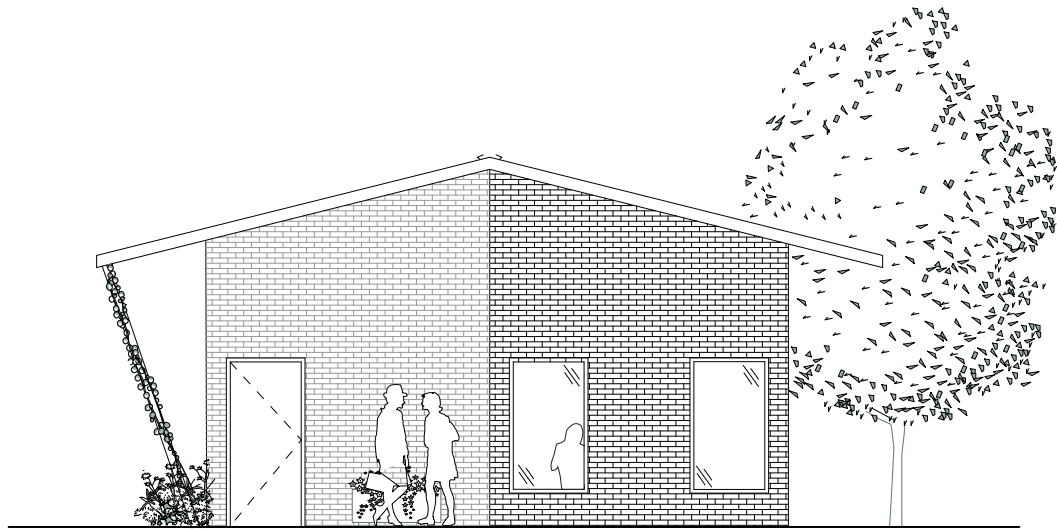

ELEVATION





Total Units: 4

Occupancy Level: 2

SqFt: 400

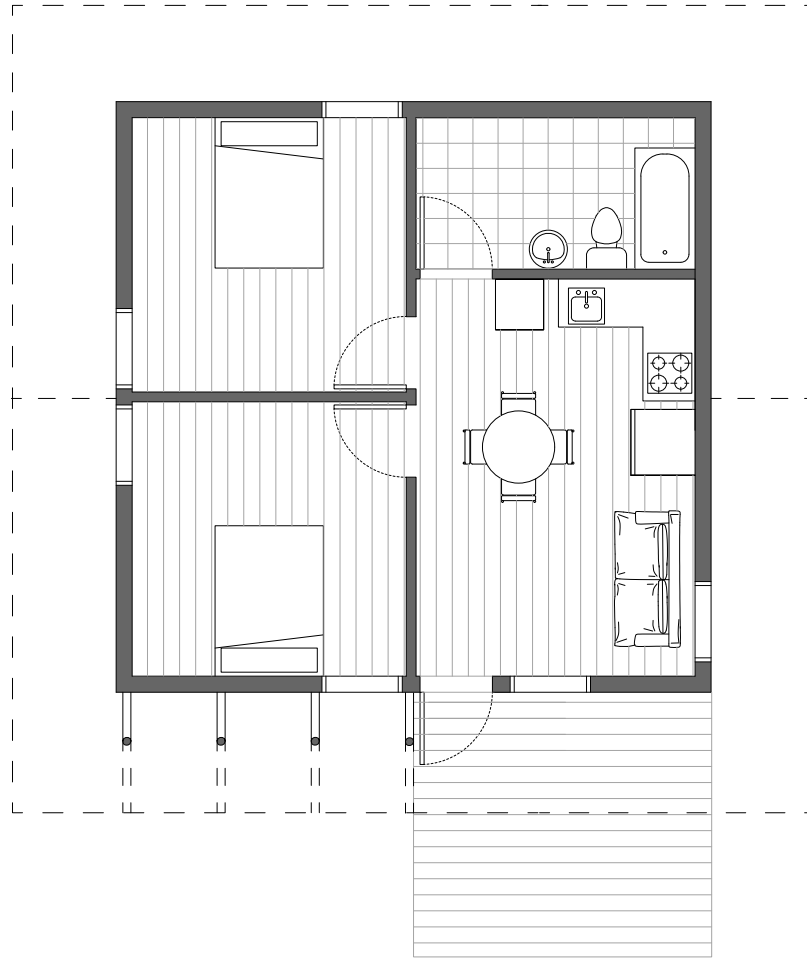

FLOOR PLAN

5

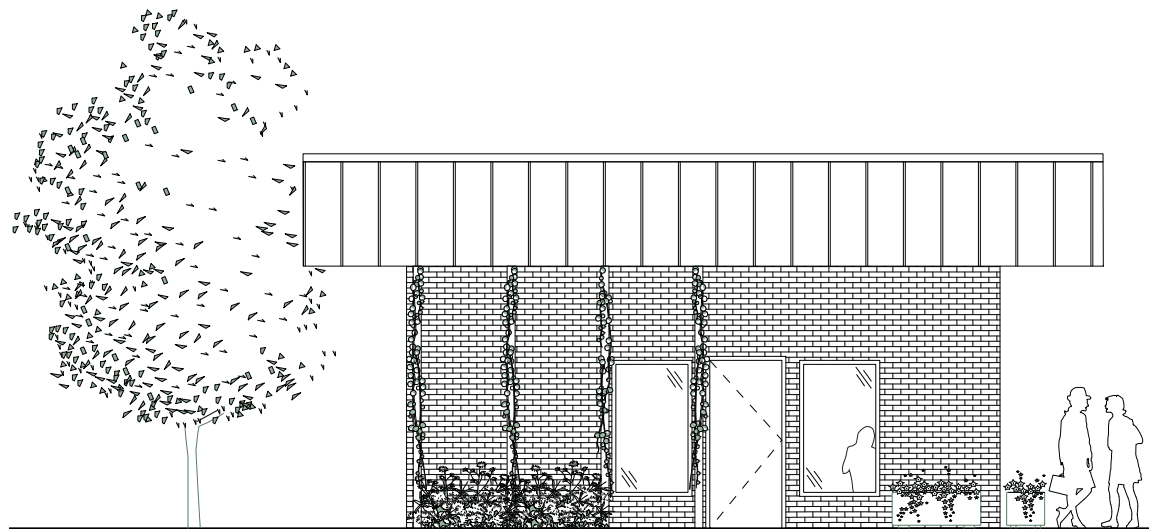

ELEVATION

5



Total Units: 6

Occupancy: 4

SqFt: 543

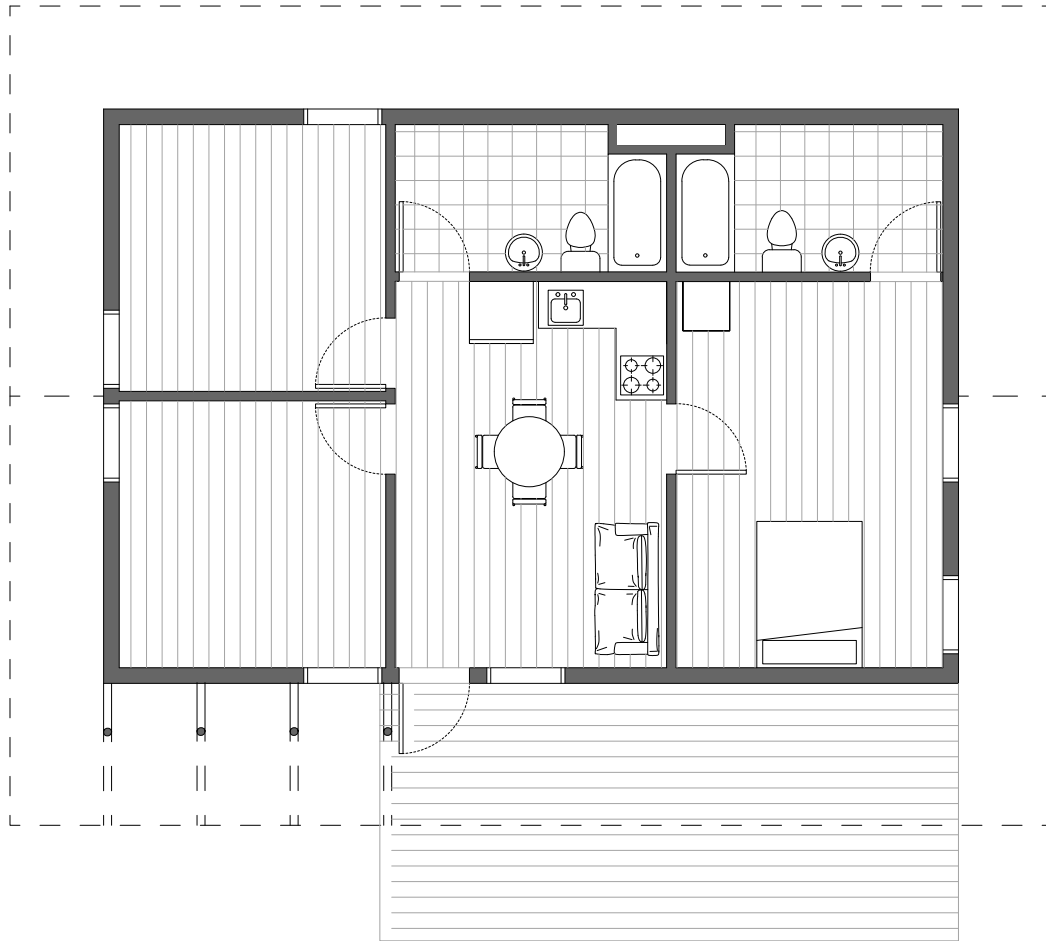

FLOOR PLAN

5

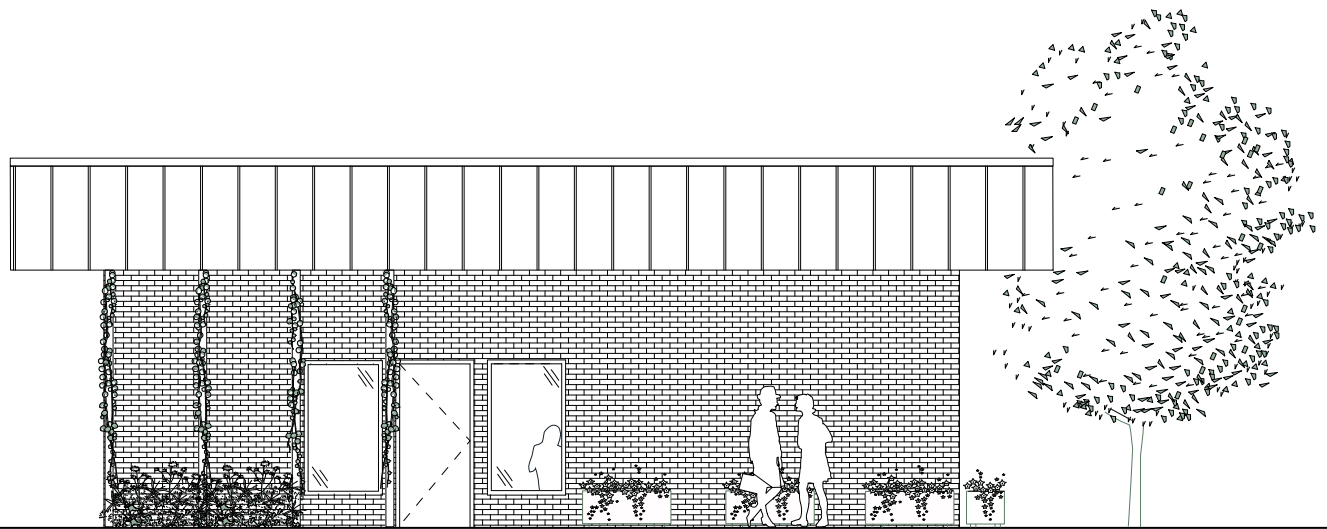

ELEVATION

5



Total Units: 8

Occupancy: 6

Sqft: 817

REFERECES

08

REFERENCES:

- Anchondo, Carlos. "After Hurricane Harvey, Texas Senator Eyes Using State's Savings for Flood Control." The Texas Tribune, The Texas Tribune, 24 Jan. 2019, www.texastribune.org/2019/01/24/senate-bill-396-flood-control-plan/.
- Barragán, James. "Hundreds Still Homeless in La Grange, a Small Texas Town Ravaged by Hurricane Harvey." Dallas News, The Dallas Morning News, 25 Aug. 2019, www.dallasnews.com/news/texas/2017/10/12/hundreds-still-homeless-in-la-grange-a-small-texas-town-ravaged-by-hurricane-harvey/.
- Bova, Gus. "The Flood Next Time." The Texas Observer, 29 Jan. 2020, www.texasobserver.org/the-flood-next-time/."Effects of Hurricane Ike in Texas." Wikipedia, Wikimedia Foundation, 13 Apr. 2020, en.wikipedia.org/wiki/Effects_of_Hurricane_Ike_in_Texas.Elliott, Janet, and Austin Bureau.
- "Texas Leaders Blast FEMA for Hurricane Ike Response." Houston Chronicle, Houston Chronicle, 9 Aug. 2011, www.chron.com/news/houston-texas/article/Texas-leaders-blast-FEMA-for-Hurricane-Ike-1789822.php.
- "Emergency Operations Training Center (EOTC)." TEEX.ORG, teex.org/Pages/about-us/emergency-operations-training-center.aspx.Fayette County Public Safety, fayettecountyga.gov/public_safety.htm.
- "FEMA Flood Map Service Center: Search By Address." View/Print FIRM: View an Image of the FIRM Panel or Print a FIRMette for Your Chosen Location. NOTE: This Is a Static Map and Has Not Been Updated since the Effective Date. Please Refer to Any Amendments or Revisions (LOMC) in the Changes to This FIRM Section., msc.fema.gov/portal/search?AddressQuery=la+grange,+texas#searchresultsanchor.
- "Flood Zone Lookup." LSC, www.lsc.gov/flood-zone-lookup.Gill.
- "More Storms Expected to Soak Houston Area on Thursday and Friday." HoustonChronicle.com, Houston Chronicle, 5 June 2019, www.houston-chronicle.com/news/houston-texas/houston/article/steady-downpour-slows-morning-commute-in-Houston-13938135.php#photo-17616988.
- Goard, Alyssa. "Hundreds Devastated by Harvey in La Grange Look for Long-Term Help." Kxan, 17 Sept. 2017.
- Golembo, Max, et al. "Death Toll Rises to 5 as Flooding Paralyzes Houston Area." ABC News, ABC News Network, 21 Sept. 2019, abcnews.go.com/US/imelda-dumps-feet-rain-parts-texas/story?id=65739994.
- Gomez, Alan. "10 Years Later, Officials Still Learning from Hurricane Rita." USA Today, Gannett Satellite Information Network, 23 Sept. 2015, www.usatoday.com/story/news/nation/2015/09/22/hurricane-rita-10-year-anniversary/72577748/.
- "Historic Disaster Response to Hurricane Harvey in Texas." Historic Disaster Response to Hurricane Harvey in Texas | FEMA.gov, www.fema.gov/news-release/2017/09/22/historic-disaster-response-hurricane-harvey-texas.Hurricanes Katrina and Rita, response.restoration.noaa.gov/oil-and-chemical-spills/significant-incidents/hurricanes-katrina-and-rita.
- "Incident Management." Ready.gov, www.ready.gov/business/implementation/incident."Installation Manuals."
- Ceco Metal Building Systems, www.cecobuildings.com/resources/installation-manuals/.Jeff.
- "Preparation, Response and Lessons Learned from Hurricane Harvey." JEMS, 2 Sept. 2019, www.jems.com/2018/03/01/preparing-for-catastrophe/.
- "La Grange Still Recovering One Year Removed from Hurricane Harvey Devastation." KVUE, 23 Aug. 2018, www.kvue.com/article/weather/harvey/la-grange-still-recovering-one-year-removed-from-hurricane-harvey-devastation/269-587048056.
- "La Grange, Texas Population 2020." La Grange, Texas Population 2020 (Demographics, Maps, Graphs), worldpopulationreview.com/us-cities/la-grange-tx-population/.
- "La Grange, Texas Population 2020." La Grange, Texas Population 2020 (Demographics, Maps, Graphs), worldpopulationreview.com/us-cities/la-grange-tx-population/.
- McGlinchy, Audrey. "'We've Never Seen Anything Like This Before': La Grange Rebuilds After Harvey." KUT, www.kut.org/post/weve-never-seen-anything-la-grange-rebuilds-after-harvey.Metal Buildings 101 – the Basics of Metal Building Systems Construction., www.starbuildings.com/rc_metal-buildings101.html.
- "Minimum Pitch For Metal Roofing." ContractorTalk, www.contractortalk.com/f15/minimum-pitch-metal-roofing-6312/index2/.

Moran, Kevin, and Harvey Rice. "Victims of Humberto Assess Damage." Houston Chronicle, 12 Sept. 2007, <https://www.chron.com/news/hurricanes/article/Victims-of-Humberto-assess-damage-1797752.php>.

National Archives and Records Administration, National Archives and Records Administration, georgewbush-whitehouse.archives.gov/news/releases/2005/09/20050923-3.html.

PBR and PBU Instillation Manual. 8 Mar. 2016, www.cecobuildings.com/wp-content/uploads/2018/10/PBR-PBU-Installation-Manual.pdf.

Poppe, Ryan. "Wimberley Publishing Book With Stories From Flood Survivors." Texas Public Radio, www.tpr.org/post/wimberley-publishing-book-stories-flood-survivors.

"Salvation Army in Texas Prepared for Effects of Hurricane Patricia." The Salvation Army Emergency Disaster Services, disaster.salvationarmyusa.org/news/2015/10/23/salvation-army-in-texas-prepared-for-effects-of-hurricane-patricia.

"Searchable Platform for Building Codes." UpCodes, up.codes/viewer/utah/ibc-2015/chapter/3/use-and-occupancy-classification#3.

"Sprinkler Head Spacing and Location." Archtoolbox.com, www.archtoolbox.com/materials-systems/fire-suppression/sprinklerspacing.html.staff, Science X.

"Rain Slows, but Flooding Still Threat in Southeast Texas (Update)." Phys.org, Phys.org, 4 June 2016, phys.org/news/2016-06-threat-southeast-texas.html.

"Texas Braces for Hurricane Patricia; Flood Watch Issued across the State." Los Angeles Times, Los Angeles Times, 24 Oct. 2015, www.latimes.com/nation/la-na-texas-hurricane-patricia-20151023-story.html.

Toal, Margaret, et al. "'I Can't Do This': Imelda Left Texas With at Least 5 Deaths and Historic Rainfall." The New York Times, The New York Times, 20 Sept. 2019, www.nytimes.com/2019/09/20/us/tropical-storm-imelda-houston-texas.html.

Tubbs, Sheryl. "Designing A Complete Community Center: Responsive Design in a Rural Setting." Capstone Collection, SIT Graduate Institute, 2012, digitalcollections.sit.edu/capstones/2534.

"Tuesday Aftermath of the Harvey Flood in La Grange." The Fayette County Record, 25 Jan. 2018, www.fayettecountyrecord.com/articles/2017/08/29/tuesday-aftermath-harvey-flood-la-grange.

Walters, Joanna. "Hurricane Patricia: Texas Feels Effects of Storm as Flooding Pummels State." The Guardian, Guardian News and Media, 24 Oct. 2015, www.theguardian.com/us-news/2015/oct/24/texas-flooding-hurricane-patricia-pummels-state.

THANK YOU

ANDREW TRIPP

CO-CHAIR

MICHAEL O'BRIEN

CO-CHAIR

AHMED ALI

MEMBER

SHANNON VAN ZANDT

MEMBER

RAY HOLLIDAY

PROFESSOR

